



emulate

Brain-Chip R1 Culture Guideline

11Mar2026

EG-185 Rev A

TITLE	DOCUMENT EG-185	VERSION Rev A
Brain-Chip R1 Culture Guideline	DATE 11Mar2026	PAGE 1 OF 71

Table of Contents

Please Read	2
Introduction to Emulate Organ-on-a-Chip Technology	2
Organ-Chip Consumable (Chip-R1™ Rigid Chip)	2
Pod-2™ Portable Module	3
Zoë-CM2® Culture Module	4
Orb-HM1™ Hub Module.....	6
Chip Cradle	8
Figure 6. Schematic of a chip cradle.	8
Cells	8
Media.....	9
Gas Equilibration	9
Experimental Overview	10
Workflow Overview.....	10
Required Materials	11
Equipment & Materials	11
Reagents, Media & Supplements	12
Aseptic Technique.....	13
Cell Storage.....	13
Chip Handling Techniques	13
Brain-Chip R1 Culture Guideline.....	16
Day X: Reagent Preparation	16
Day -2: Media Supplement Preparation	18
Day -1: Chip Preparation.....	19
Day 0: BMECs to Chip	24
Day 1: BMEC Rest Day	31
Day 2: Top Channel Seeding Day.....	33
Day 3: Chips to Pods and Pods to Zoë	49

TITLE	DOCUMENT	VERSION
Brain-Chip R1 Culture Guideline	EG-185	Rev A
	DATE	PAGE
	11Mar2026	2 OF 71

Day 4: Monolayer Stabilization	59
Days 5-9: Experimental Phase	61
Troubleshooting	65
Appendices	67
Reagent Aliquots	67
Media Recipes	68

Please Read

Note that iPSC-derived brain cells are particularly sensitive to temperature fluctuations. It is critical to store cells in liquid nitrogen upon receipt, specifically in the vapor phase zone of the liquid nitrogen storage unit. Proper storage will influence cell viability upon thaw. Success of the chips is highly dependent upon high percentage of cell viability (>80%) post-thaw.

Introduction to Emulate Organ-on-a-Chip Technology

This section provides an overview of key components of Emulate Organ-on-a-Chip technology, including the Chip-R1™ Rigid Chip, the Pod-2™ Portable Module, Zoë-CM2® Culture Module, and the Orb-HM1® Hub Module.

An Organ-Chip is a living, micro-engineered environment that recreates the natural physiology and mechanical forces cells experience within the human body. Pods provide the media to the Organ-Chip needed to promote cell growth while serving as the interface between an Organ-Chip and Zoë Culture Module. Zoë provides a flow of nutrient-rich media at a user-determined rate and provides the mechanical forces needed to emulate the *in vivo* physical forces by tissue. The Orb provides a mix of 5% CO₂, vacuum stretch, and power for up to four Zoë Culture Modules.

Organ-Chip Consumable (Chip-R1™ Rigid Chip)

The Chip-R1 can be configured to emulate different organ tissues, including the liver and brain. The chip connects to a Pod-2 and Zoë to recreate the body's dynamic cellular microenvironment, including tissue-to-tissue interfaces and blood flow. This guideline describes the methodology for using the Brain-Chip R1 in an experiment.

The microenvironment created within each Chip-R1 includes epithelial cells in the top channel and endothelial cells in the bottom channel, which are separated by a porous membrane to allow for cell-cell interactions like those seen *in vivo* while still allowing for fluidic independence. Cells in each channel are seeded with organ- and cell-specific extracellular matrix proteins (ECM) and, depending on cell type, can be maintained in static culture for up to four days before being connected to Zoë.

TITLE Brain-Chip R1 Culture Guideline	DOCUMENT EG-185	VERSION Rev A
	DATE 11Mar2026	PAGE 3 OF 71

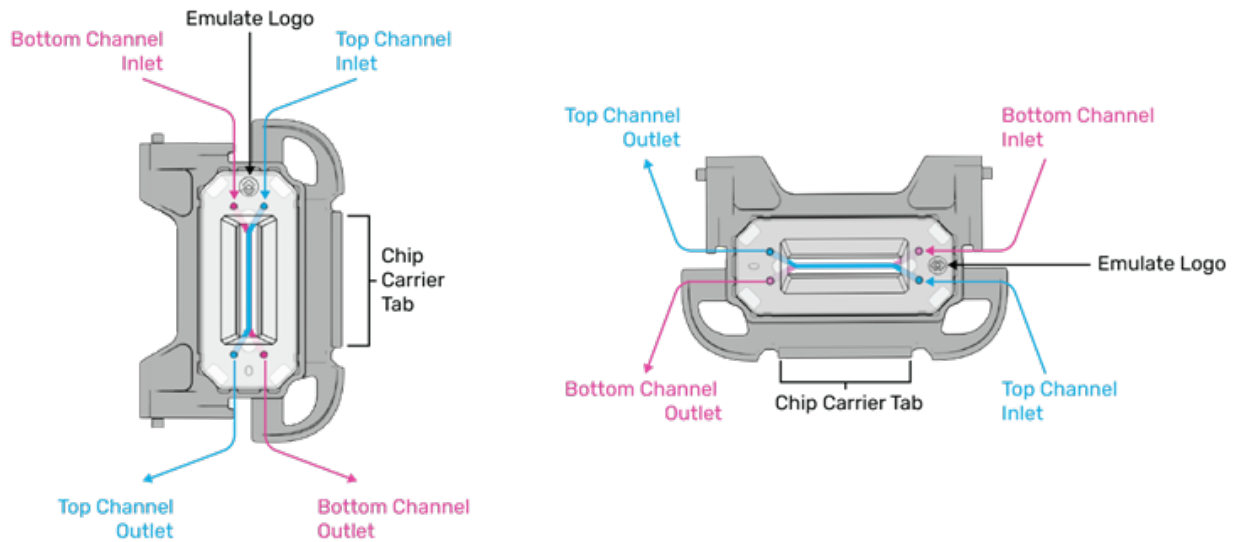

Figure 1. Schematic of vertical and horizontal orientations of a Chip-R1 in its chip carrier.

Chips are supplied pre-packaged in the chip carrier and should be maintained in the chip carrier at all times. The chip carrier is designed to hold chips in place, eliminating the need to disturb or distort the chip during preparation. In addition, the chip carrier connects securely to the Pod, which acts as the interface between Zoë and the chip. Always avoid touching the chip directly. Handle the chip carrier only by the sides, or by the tab, with gloves. Removal of the chip from the chip carrier prior to or during an experiment could result in chip failure. (The only appropriate time to remove the chip from the carrier is at end of the experiment, when the chip is no longer used for live culture of the cells.)

Pod-2™ Portable Module

The Pod-2 (referred to as “Pod” hereafter) houses the Chip-R1, supplies media, and enables compatibility with microscopes and other analysis equipment. Pod-2 is compatible with Chip-R1 only. Its height of 41.5 mm allows Organ-Chips to be easily transported within the Pods and placed on standard microscopes for imaging as well as other hardware and analysis equipment.

The Pod's 4-mL reservoirs allow users to introduce nutrient media, precisely control dosing to test drugs or other inputs, and sample chip effluent.

TITLE Brain-Chip R1 Culture Guideline	DOCUMENT EG-185	VERSION Rev A
	DATE 11Mar2026	PAGE 4 OF 71

Pod™ Components

1. Pod Reservoir Lid
2. Pod Reservoir
3. Organ-Chip
4. Chip Carrier

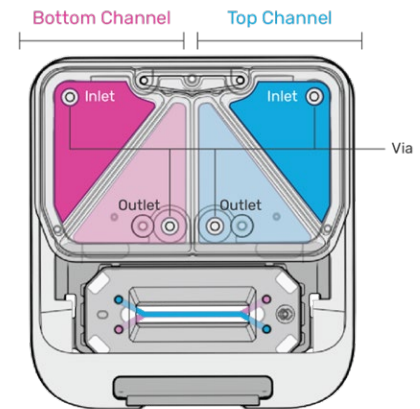
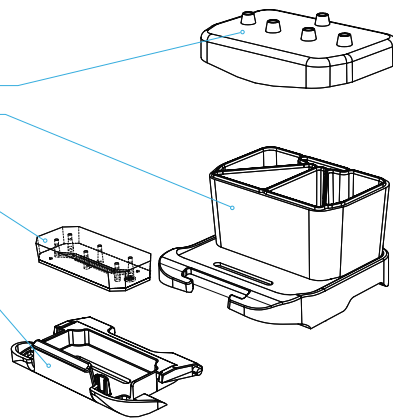

Figure 2. Pod-2 schematic demonstrating parts and the orientation of the bottom and top inlet and outlet reservoirs.

Zoë-CM2® Culture Module

The Zoë-CM2 Culture Module (referred to as “Zoë” hereafter) is designed to sustain the life of cells within Emulate’s Organ-Chips. It provides the dynamic flow of media and the mechanical forces that help recreate the microenvironment cells experience *in vivo*. The instrument automates the precise conditions needed for simultaneous cell culture of up to 12 Organ-Chips.

Zoë enables independent control of the rate at which media flows through channels of the Organ-Chips as well as stretch parameters—including frequency and amplitude (only for Emulate Chip-S1® Stretchable Chips and Chip-A1™ Accessible Chips). Zoë also comes with automated algorithms to prime the Pods’ fluidic channels with media and programming to maintain the culture microenvironment to ensure optimal cell performance.

TITLE Brain-Chip R1 Culture Guideline	DOCUMENT EG-185	VERSION Rev A
	DATE 11Mar2026	PAGE 5 OF 71

Components

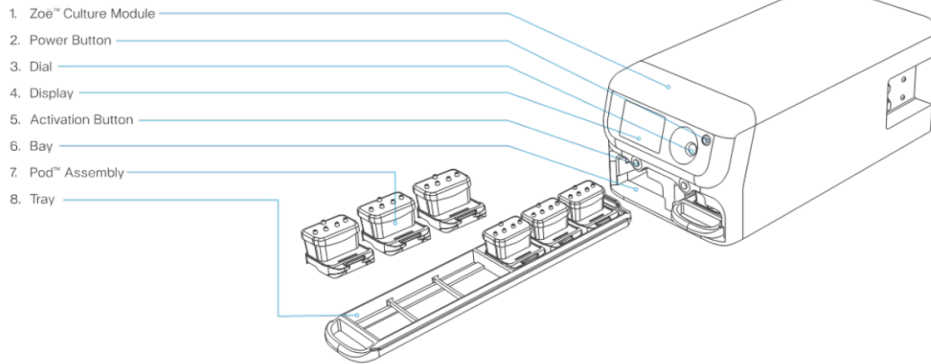

Figure 3. Schematic of a Zoë Culture Module.

CAUTION



Careful consideration must be taken when selecting the specific Emulate Organ-Chip consumable type to be used with a Zoë. The consumable type must be configured on the Zoë User Interface (UI) according to the chip being used (Chip-S1, Chip-A1, or Chip-R1). This setting impacts the Prime, Regulate, and Flow parameters for the chip. A mismatch between the UI setting and the physical consumable could lead to instrument failure.

Chip-R1 can only be used with Pod-2. Chip-S1 and Chip-A1 can only be used with Pod-1 or Pod S1/A1 (after March 2026) and is not compatible with this guideline.

To use Chip-R1 on Zoë-CM1, ensure the firmware is on v1.2.4 or above
 To use Chip-R1 on Zoë-CM2, ensure the firmware is on v1.4.5 or above*

Firmware updates can be performed through [Utility Hub](#) on the Emulate website.

**If your Zoë-CM2 is on v1.3.0 or below, please contact Emulate Support.*

TITLE	DOCUMENT EG-185	VERSION Rev A
Brain-Chip R1 Culture Guideline	DATE 11Mar2026	PAGE 6 OF 71

 ZOE 123456

Prime Cycle

Regulate Cycle Start

Flow  **Chip-R1**

LOCATION	MEDIA	RATE
Top	Liquid	20 μ L/h
Bottom	Liquid	20 μ L/h

Stretch

PARAMETER	RATE
Strain	0 %
Frequency	0 Hz



Figure 4. Example UI interface on a Zoë-CM2 with Chip-R1 settings and top and bottom channels set to 20 μ L/h.

Follow the below steps to select the Chip-R1 as the consumable type:

- | Step | Action |
|------|--|
| 1 | Use the Dial to highlight “Chip-S1” or “Chip-R1” on the display. |
| 2 | Press the Dial Button to select the displayed chip type. |
| 3 | Rotate the Dial to toggle to “Chip-R1” |
| 4 | Press the Dial Button to select “Chip-R1” |

Orb-HM1™ Hub Module

The Orb is a central hub that connects up to four Zoë Culture Modules. It provides a simple solution for installing and operating the Zoë Culture Module within the lab environment. The Orb delivers a mix of 5% CO₂, and vacuum stretch (when appropriate), from standard lab connections. It generates a 5% CO₂ supply of gas to Zoë by combining air with an external 100% carbon dioxide supply (or from a portable CO₂ canister for increased flexibility) in a controlled mixture. The Orb also contains four individual power ports.

TITLE Brain-Chip R1 Culture Guideline	DOCUMENT EG-185	VERSION Rev A
	DATE 11Mar2026	PAGE 7 OF 71

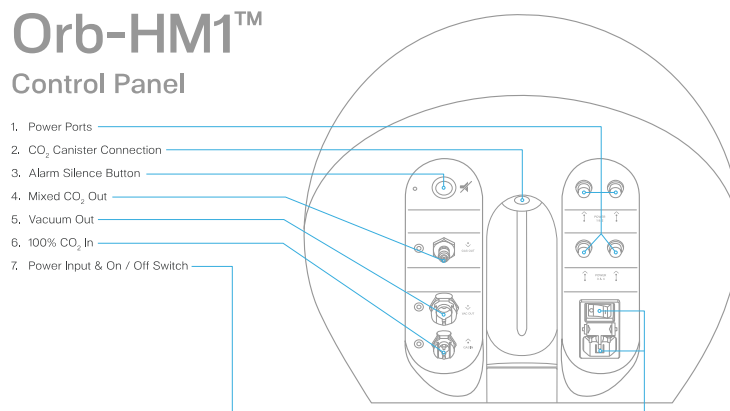
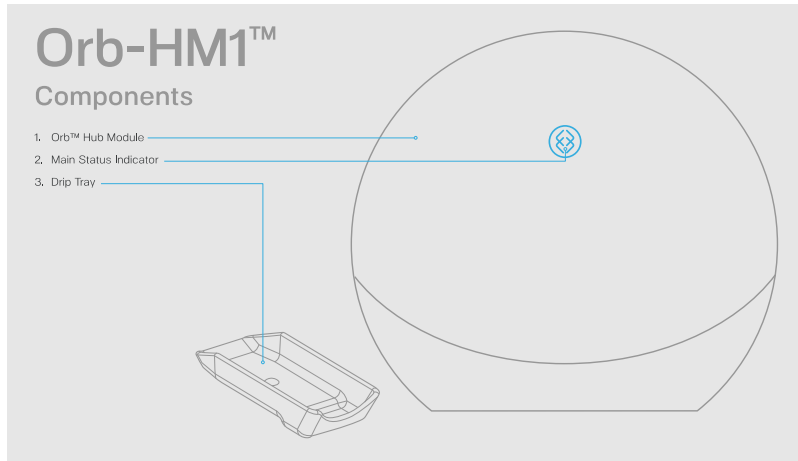

Figure 5. Schematic of the Orb-HM1 Hub Module.

TITLE Brain-Chip R1 Culture Guideline	DOCUMENT EG-185	VERSION Rev A
	DATE 11Mar2026	PAGE 8 OF 71

Chip Cradle

The Chip Cradle is an accessory that holds and organizes up to six chips. It offers several benefits:

- It allows inversion of the chips during seeding.
- It has a DPBS reservoir that keeps the chips humidified.
- It is made from autoclavable plastic.
- It contains slots with numbered labels to help keep chips organized.

Chip Cradle

Configuration

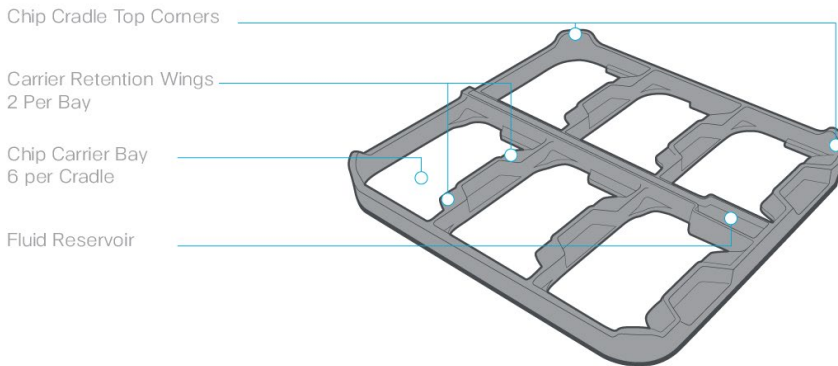

Figure 6. Schematic of a chip cradle.

Cells

The iPSC-derived cells included within the Brain-Chip R1 BioKit are isolated, differentiated, stored, and handled by FUJIFILM Cellular Dynamics, Inc. (FCDI). Upon receipt of the Brain-Chip R1 cells from FCDI, store cells in liquid nitrogen, specifically in the vapor phase zone of the liquid nitrogen storage unit. Proper storage will influence cell viability upon thaw. iPSC-derived brain cells are particularly sensitive to temperature fluctuations. The success of the chips is highly dependent upon the high percentage of cell viability (>80%), post-thaw.

TITLE	DOCUMENT	VERSION
Brain-Chip R1 Culture Guideline	EG-185	Rev A
	DATE	PAGE
	11Mar2026	9 OF 71

Media

Custom media will arrive frozen along with the Brain-Chip R1 cell shipment from FCDI. Brain-Chip R1 custom media is also manufactured, stored, and handled by FUJIFILM Cellular Dynamics, Inc. (FCDI). Frozen media should be stored at -20°C upon receipt. To thaw, place the media in a 4°C refrigerator or on ice and allow the media to thaw. It is not recommended to thaw the media at room temperature or in any kind of warmed water bath or bead bath.

Gas Equilibration

Proper gas equilibration of media is essential for successful Organ-Chip culture. As the system is sensitive to bubbles, all media must be equilibrated to 37°C and excess gas removed prior to use in the chips and in Zoë. To do this, 37°C medium is placed under vacuum using the 0.45 µm PVDF filter of a Steriflip® conical filter unit. Failure to carry out this step could lead to failure of the chips in the experiment.

It is also important to look for bubbles throughout the experiment. Observed bubbles can often be flushed out of the system to avoid a disruption in medium flow and / or improper surface coverage. However, instances of chips with visible bubbles or blocked flow should be recorded and considered when analyzing experimental data.

TITLE	DOCUMENT	VERSION
Brain-Chip R1 Culture Guideline	EG-185	Rev A
	DATE	PAGE
	11Mar2026	10 OF 71

Experimental Overview

Workflow Overview

Day X: Reagent Preparation

- Aliquot reagents (media supplements, ECM, etc.)

Day -2: Media Preparation

- Thaw Brain Channel Medium (Top) at 4°C overnight
- Thaw Vascular Channel Medium (Bottom) at 4°C overnight

Day -1: Chip Preparation

- Prepare ECM solution
- Coat chips with ECM

Day 0: BMECs to Chips

- Incubate ECM-coated chips at 37°C for +4 hours
- Warm Brain Channel Medium and Vascular Channel Medium at 37°C for 1 hr
- Prepare Complete Vascular Channel Seeding Medium
- Wash ECM out of chips
- Thaw & seed the bottom channel with BMECs (12.23M cells/mL)
- Incubate inverted chips at 37°C overnight

Day 1: BMECs Stabilization

- Rest day and media replenishment

Day 2: Brain Cells to Chips

- Prepare Complete Brain Channel Pericyte Seeding medium
- Thaw & seed the top channel with pericytes (690K cells/mL)
- Incubate chips at 37°C for 2-4 hours
- Prepare Complete Brain Channel Seeding medium
- Thaw & seed the top channel with GABANeurons, microglia, and astrocytes (2.73M cells/mL, 649K cells/mL, 909K cells/mL, respectively)
- Incubate chips at 37°C for 2 hours
- Insert tips with Complete Vascular Channel Maintenance medium and Base Brain Channel Medium for overnight incubation

Day 3: Chips to Pods and Pods to Zoë

- Gas equilibration of media
- Prime Pods
- Wash chips
- Chips to Pods
- Pods to Zoë

TITLE Brain-Chip R1 Culture Guideline	DOCUMENT EG-185	VERSION Rev A
	DATE 11Mar2026	PAGE 11 OF 71

Day 4: Monolayer Stabilization

- Rest day and media replenishment

Days 5-9: Experimentation Phase

- Sampling and media replenishment

Required Materials

Ensure all equipment, materials, and reagents are accessible prior to beginning each experiment. Exact catalog numbers are provided for specific materials required for successful experiments.

Equipment & Materials

Equipment	Description	Supplier	Catalog Number
Zoë-CM2 Culture Module	1 per 12 chips	Emulate	ZOE-CM2
Orb-HM1 Hub Module	1 per 4 Zoës	Emulate	ORB-HM1
Chip-R1 Chip	12 per Zoë	Emulate	-
Pod-2 Portable Modules	1 per Chip-R1	Emulate	-
Chip Cradle	Autoclaved, 1 per 6 chips	Emulate	CHIP-CRD
Steriflip-HV Filters	0.45 µm PVDF filter Sterile	EMD Millipore	SE1M003M00
120 mm cell square dish	Sterile, 1 per 6 chips	VWR	82051-068
Handheld vacuum aspirator	-	Corning	4930
Aspirating pipettes	2 mL, polystyrene, individually wrapped	Corning / Falcon	357558
Aspirating tips	Sterile (autoclaved)	-	-
Serological pipettes	2 mL, 5 mL, 10 mL, and 25 mL; low endotoxin, sterile	-	-
Pipette	P20, P200, and P1000	-	-
Pipette tips	P20, P200, and P1000 sterile, low adhesion	-	-
Conical tubes	15 mL and 50 mL polypropylene, sterile	-	-
Eppendorf Tubes®	1.5 mL, sterile	-	-

TITLE Brain-Chip R1 Culture Guideline	DOCUMENT EG-185	VERSION Rev A
	DATE 11Mar2026	PAGE 12 OF 71

Aluminum foil	-	-	-
Parafilm®	-	-	-
Microscope (with camera)	For brightfield imaging	-	-
Hemocytometer	-	-	-
Manual counter	-	-	-
Water bath (or beads)	Set to 37°C	-	-
Vacuum set-up	Minimum pressure: -70 kPa	-	-
Ice bucket	-	-	-
70% ethanol and wipes	For surface sterilization	-	

Reagents, Media & Supplements

Reagent	Description	Supplier	Catalog Number
Emulate Brain-Chip Brain Channel Medium	Base medium for the top channel	FUJIFILM Cellular Dynamics, Inc.	RGT-BRBC-150
Emulate Brain-Chip Vascular Channel Medium	Base medium for the bottom channel	FUJIFILM Cellular Dynamics, Inc.	RGT-BRVC-150
Collagen type IV	Human placenta	Sigma	C5533
Fibronectin	Human plasma	Corning	356008
Laminin	Mouse, 5 mg	Sigma	CC095-5MG
Trypan blue	0.4% solution	Sigma	93595
Human Serum, platelet poor human plasma (PPP)	Sterile-filtered	Sigma	P2918
B27	50X	GIBCO	17504-044
Y-27632 (ROCKi)	5 mg	StemCell	72304
Cell Culture Grade Water	Sterile, Water	Corning	MT25055CV
CNTF	20 µg	Peptotech	450-13-20UG
Ethanol (140 Proof)	Liquid	Sigma	793213

TITLE	DOCUMENT	VERSION
Brain-Chip R1 Culture Guideline	EG-185	Rev A
	DATE	PAGE
	11Mar2026	13 OF 71

Aseptic Technique

Prepare and sanitize the work surface of the biosafety cabinet (BSC) before beginning experimental work. Ensure that the workspace within the BSC is organized and free from clutter. Arrange tips, media, and other necessary materials in the sterile field, easily within reach, without blocking the path of airflow.

Sanitize all reagents and materials entering the BSC with 70% ethanol. Spray and wipe thoroughly. Always avoid touching the chip directly. Handle the chip carrier only by the sides or by the tab with gloves. Never remove the chip from the chip carrier prior to or during an experiment.

Cell Storage

Cryopreserved cells must be stored in liquid nitrogen. Severe damage to cell membrane and cytoskeletal components can result from chronic temperature fluctuations. Never store in dry ice or in a -80°C freezer.

Chip Handling Techniques

Always work with chips within the chip carrier in a sterile environment, such as the BSC.

When pipetting to fill each channel, 50 μL volume is generally used for the top channel, and 20 μL is used for the bottom channel. These volumes allow for simple pipetting and a slight overfill to avoid bubbles or dry channels. All wash steps, unless otherwise stated, are performed using 200 μL of the specific wash solution.

While 50 μL (top channel) and 20 μL (bottom channel) are standard volumes used throughout the guideline, there can be some flexibility in the actual volumes used:

Top Channel: 25–50 μL

Bottom Channel: 15–20 μL

The specific channel and membrane dimensions of Chip-R1 are outlined below:

Top Channel

Top width x height x bottom width dimensions	950 μm x 1,000 μm x 1,000 μm
Area	25.66 mm^2
Volume	24.52 μL
Imaging distance from bottom of chip to top of membrane	172 μm

Bottom Channel

Width x height dimensions	1,050 μm x 100 μm
Area	29.46 mm^2
Volume	2.97 μL

TITLE	DOCUMENT	VERSION
Brain-Chip R1 Culture Guideline	EG-185	Rev A
	DATE	PAGE
	11Mar2026	14 OF 71

Membrane

Pore diameter	3.0 μm
Pore spacing	Randomized (track-etched membrane)
Thickness	22 μm
Porosity	2.8%

Co-Culture Region

Area	16.56 mm^2
------	---------------------

A P200 pipette with a sterile pipette tip is used to add solution directly to the channels of the chip, as when coating, washing, and seeding cells prior to engaging the chip to Zoë. To introduce solution to the channels, place the pipette tip perpendicular to chip channel inlet, ensuring that the tip is securely in the port, and steadily dispense liquid through the channel.

Note: Always introduce liquid to the endothelial channel before the epithelial channel.

TITLE	DOCUMENT EG-185	VERSION Rev A
Brain-Chip R1 Culture Guideline	DATE 11Mar2026	PAGE 15 OF 71



There is additional resistance in the bottom channel of Chip-R1 compared to Chip-S1. Therefore, when pipetting into the bottom channel, depress the plunger fully and hold the pipette at the port for several seconds to allow the full volume to be pipetted through the bottom channel.



When aspirating from the gasket window, take precaution NOT to make contact with the channel feature itself. The top gas exchanger film can easily be punctured by a pipette tip.

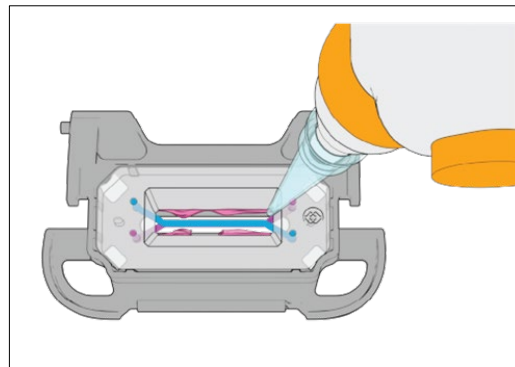

Figure 7. Image demonstrating where to aspirate excess media on the gasket window of a Chip-R1 without making contact.

Note on Aspiration: Careful consideration must be given to aspiration steps during Chip-R1 seeding. Residual liquid over the outlet ports may be a contributing factor to the formation of cell distribution gradients when handling the chips post-seeding.

Suggestions for aspiration and avoiding gradients:

1. Aspirate excessive volume from the outlets with a vacuum aspirator.
2. Do not work directly over the port as this may cause the cell medium to aspirate from the channel itself.
3. Do not drag the aspirator tip across the top of the chip as this can cause scratches on the top layer.

TITLE	DOCUMENT EG-185	VERSION Rev A
Brain-Chip R1 Culture Guideline	DATE 11Mar2026	PAGE 16 OF 71

Brain-Chip R1 Culture Guideline

Day X: Reagent Preparation

Goals:

- Reconstitute and aliquot reagents needed for Brain-Chip R1 culture

Key Steps:

- Reconstitute ECM components and aliquot single-use volumes
- Aliquot single-use volumes of supplements as needed for the Emulate Brain-Chip Brain Channel Medium for seeding
- Aliquot single-use volumes of supplements as needed for the Emulate Brain-Chip Vascular Channel Medium for seeding and culture maintenance

Required Materials:

- Cell culture grade water
- Dulbecco's PBS (DPBS -/-) (without Ca²⁺, Mg²⁺) (1X)
- ECM Components:
 - Collagen IV, Fibronectin, Laminin
- Supplements for Vascular Channel Seeding and Maintenance Media:
 - B27, Human Serum (PPP)
- General seeding media supplements:
 - Y-27632 (ROCKi), CNTF
- 1.5 mL or 0.5 mL Eppendorf tubes
- 15 mL conical tubes
- Serological pipettor and tips
- Pipette and tips
- Ice and ice bucket
- 70% ethanol

Aliquot Reagents

Aliquot the reagents before use to avoid multiple freeze-thaw cycles of the stock solutions.

Extracellular Matrix (ECM) Components

Reagent	Source	Catalogue Number	Conc. [Stock]	Amount	Volume	Solvent	Storage
Fibronectin	Corning	356008	1 mg / mL	5 mg	5 mL	Cell culture grade water	-20°C
Laminin	Sigma	CC095-5MG	Variable	5 mg	5 mL	-	-20°C
Collagen IV	Sigma	C5533-5MG	1 mg / mL	5 mg	5 mL	Cell culture grade water	-20°C

TITLE Brain-Chip R1 Culture Guideline	DOCUMENT EG-185	VERSION Rev A
	DATE 11Mar2026	PAGE 17 OF 71

- Resuspend ECM according to manufacturer's instructions.
- Aliquot to single-use volumes and store at -20°C.

Supplements for Vascular Channel Seeding and Maintenance Media

Reagent	Source	Catalogue Number	Conc. [Stock]	Volume	Solvent	Storage
B27	GIBCO	17504-044	50X	10 mL	-	-20°C
Human Serum (PPP)	Sigma	P2918-20ML	100%	20 mL	-	-20°C

- Aliquot each supplement to single-use volumes.
- Store aliquots as indicated. Those stored at -20°C can be thawed at 4°C and maintained for up to one week.

General Seeding Supplements

Reagent	Source	Cat #	Conc. [Stock]	Mass	Volume	Solvent	Storage
Y-27632 (ROCKi)	StemCell	72304 5MG	0.01M	5 mg	1.56 mL	DPBS (1X)	-20°C
CNTF	PeproTech	450-13-20UG	100 µg/mL	20 µg	200 µL	Cell Culture Grade Water	-20°C

- Resuspend each supplement to the stock concentration in the table above or according to manufacturer's instructions, if need be.
- Aliquot each supplement to single-use volumes and store at -20°C.

TITLE	DOCUMENT	VERSION
Brain-Chip R1 Culture Guideline	EG-185	Rev A
	DATE	PAGE
	11Mar2026	18 OF 71

Day -2: Media Supplement Preparation

Goals:

- Allow Emulate Brain-Chip Brain Channel Medium time to thaw prior to ECM preparation
- Allow Emulate Brain-Chip Vascular Channel Medium time to thaw prior to ECM preparation

Key Steps:

- Remove one bottle of Emulate Brain-Chip Brain Channel Medium and one bottle of Emulate Brain-Chip Vascular Channel Medium from the -20°C freezer and set in a 4°C refrigerator to thaw overnight

Required Materials:

- Emulate Brain-Chip Brain Channel Medium
 - Emulate Brain-Chip Vascular Channel Medium
1. Take one bottle of Emulate Brain-Chip Brain Channel medium and one bottle of Emulate Brain-Chip Vascular Channel Medium from the -20°C freezer and set in a 4°C refrigerator to thaw overnight.

TITLE	DOCUMENT	VERSION
Brain-Chip R1 Culture Guideline	EG-185	Rev A
	DATE	PAGE
	11Mar2026	19 OF 71

Day -1: Chip Preparation

Goals:

- Prepare chips
- Coat top & bottom channels with a mixture of ECM proteins for cell attachment

Key Steps:

- Open and plate chips
- Prepare ECM-1T and ECM-2B solutions
- Introduce ECM-1T and ECM-2B solutions to respective channels

Required Materials:

- Emulate Brain-Chip Brain Channel Medium
- Chip-R1 (12 chips per Zoë)
- Chip Cradle (6 chips per cradle)
- 15 mL conical tubes
- DPBS (- / -) aliquot at 4°C
- Collagen IV (Stock 1 mg/mL)
- Fibronectin (Stock 1 mg/mL)
- Laminin (Stock variable; see label)
- 70% ethanol
- 120 mm square cell culture dish
- Ice and ice bucket
- Pipettes and filtered tips
- Aspirator and sterile tips

TITLE	DOCUMENT	VERSION
Brain-Chip R1 Culture Guideline	EG-185	Rev A
	DATE	PAGE
	11Mar2026	20 OF 71

Prepare Chips

1. Spray chip packaging, 120 mm square cell culture dish, and Chip Cradle with 70% ethanol and bring into the BSC.
2. Open the Chip Cradle sterile packaging and then place the cradle into the 120 mm square dish, making sure the Chip Cradle is oriented properly with the corners facing up.
3. Open the chip packaging carefully and then place the first chip into the cradle by sliding the back of the carrier under the tabs on the cradle (See Figure 8).

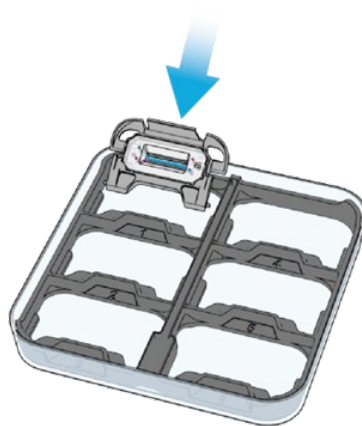

Figure 8: Place chips by sliding under the tab of the Chip Cradle.

4. Repeat as necessary for all of the chips included in the experiment.

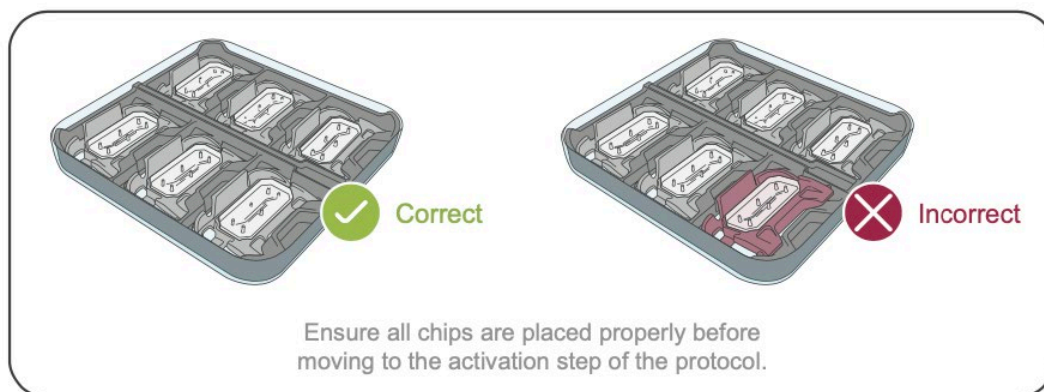

Figure 9: Ensure chips are placed with Chip Cradle properly, sitting flush with the square dish and not tilted.

5. Label each chip with ID numbers on the chip carrier tab.

TITLE	DOCUMENT EG-185	VERSION Rev A
Brain-Chip R1 Culture Guideline	DATE 11Mar2026	PAGE 21 OF 71

Prepare ECM Solutions

The ECM solutions are prepared fresh for each experiment on ice. The ECM solutions will be used to coat the top and bottom channels of the chips.

For the brain channel (top) of the Brain-Chip R1, the ECM (ECM-1T) working concentration is:

- Laminin: 30 µg / mL
- Emulate Brain-Chip Brain Channel Medium

For the vascular channel (bottom) of the Brain-Chip R1, the ECM (ECM-2B) working concentration is:

- Collagen IV: 400 µg / mL
- Fibronectin: 100 µg / mL
- Laminin: 20 µg / mL
- DPBS 1x

1. Bring an ice bucket and ice to the BSC.
2. Thaw single-use aliquots of fibronectin, collagen IV, and laminin on ice. Always maintain all ECM components and mixtures on ice.
3. Set aside a volume of Emulate Brain-Chip Brain Channel Medium and DPBS 1x in the ice, as well as two 15 mL conical tubes, one for each ECM solution.
4. Calculate total volume of ECM solutions needed to coat all chips.

- Volume calculated per channel per chip = 200 µL
- For every 12 chips to coat, prepare 3 mL of ECM solution
- (12 chips x 200 µL / chip + extra 600 µL = 3 mL of ECM solution)
- Extra is included to account for pipetting loss

A. ECM-1T Calculation Example ($C_1V_1 = C_2V_2$)

Laminin stock concentration: 1.9 mg/mL* (C_1)

Laminin final concentration: 0.030 mg/mL (C_2)

Stock volume: Laminin (V_1)

Final volume of ECM solution: 3 mL (V_2)

Laminin

$$(1.9 \text{ mg/mL}^*) \times (Y \text{ mL}) = (0.030 \text{ mg/mL}) \times (3 \text{ mL})$$

$$Y = 47.37 \text{ } \mu\text{L of Laminin}$$

Emulate Brain-Chip Brain Channel Medium

$$= (\text{total volume of ECM needed}) - (\text{volume of stock Laminin})$$

$$= 3000 \text{ } \mu\text{L} - 47.37 \text{ } \mu\text{L}$$

$$= 2952.63 \text{ } \mu\text{L of Emulate Brain-Chip Brain Channel Medium}$$

TITLE Brain-Chip R1 Culture Guideline	DOCUMENT EG-185	VERSION Rev A
	DATE 11Mar2026	PAGE 22 OF 71

B. ECM-2B Calculation Example ($C_1V_1 = C_2V_2$)

	Stock Concentration (C_1)	Final Concentration (C_2)
Collagen IV	1 mg/mL	0.4 mg/mL
Fibronectin	1 mg/mL	0.1 mg/mL
Laminin	1.9 mg/mL*	0.02 mg/mL

Stock volume: Collagen IV / Fibronectin / Laminin (V_1)

Final volume of ECM solution: 3 mL (V_2)

Collagen IV

$$(1 \text{ mg/mL}) \times (Y \text{ mL}) = (0.40 \text{ mg/mL}) \times (3 \text{ mL})$$

Fibronectin

$$(1 \text{ mg/mL}) \times (Y \text{ mL}) = (0.10 \text{ mg/mL}) \times (3 \text{ mL})$$

Laminin

$$(1.9 \text{ mg/mL}^*) \times (Y \text{ mL}) = (0.02 \text{ mg/mL}) \times (3 \text{ mL})$$

$$Y = 1200 \text{ } \mu\text{L Collagen IV} / 300 \text{ } \mu\text{L Fibronectin} / 31.58 \text{ } \mu\text{L Laminin}$$

DPBS 1x

$$= (\text{total volume of ECM needed}) - (\text{volume of stock Collagen IV}) - (\text{volume of stock Fibronectin}) - (\text{volume of stock Laminin})$$

$$= 3000 \text{ } \mu\text{L} - 1200 \text{ } \mu\text{L} - 300 \text{ } \mu\text{L} - 31.58 \text{ } \mu\text{L}$$

$$= 1468.42 \text{ } \mu\text{L of DPBS 1x}$$

*Laminin stock concentration is variable; check manufacturer's label for accurate concentration.

5. Combine components to prepare both ECM working solutions. One for the top channel (ECM-1T) and one for the bottom channel (ECM-2B).
6. Keep the ECM solutions on ice until it is needed.

Coat Chips with ECM

1. Using a P200 pipette and sterile 200 μL filtered pipette tip, take up 200 μL of the ECM-2B solution.
2. Carefully introduce the ECM-2B solution into the bottom channel inlet until a small ECM droplet forms on the bottom outlet port.
 - a. **Note:** The pipette tip is inserted into the bottom channel inlet port. The tip should gently slide in until it stops. **Do not force the tip** or put a lot of pressure when inserting the tip so as not to puncture the chip.

TITLE	DOCUMENT EG-185	VERSION Rev A
Brain-Chip R1 Culture Guideline	DATE 11Mar2026	PAGE 23 OF 71

3. Using a sterile aspiration tip, aspirate the outflow until the full volume of 200 μL is pushed through. Do not aspirate the solution from the channel and be careful to not introduce air into the channel.
4. Repeat using the ECM-1T solution, introducing the pipette tip into the top channel inlet until a small ECM droplet forms on the top outlet port, then push the full 200 μL volume through, while aspirating the outflow.
5. Using the respective ECM solutions for each channel, leave small droplets of excess ECM solution on both ports to prevent evaporation (Figure 10).

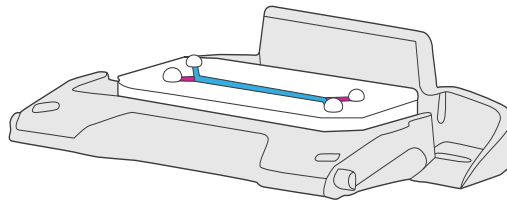

Figure 10: Chip in chip carrier with small individual droplets of ECM solution at ports

6. Inspect channels to ensure that no bubbles are present. If bubbles are present, dislodge by washing the channel with its respective ECM solution until all bubbles have been removed.
7. Repeat steps 1 through 6 for each chip.
8. To prevent evaporation during ECM incubation, fill the central reservoir with 0.75 mL of DPBS 1x (Figure 11), place the lid onto the 120 mm square dish, and incubate overnight at 4°C.
 - a. Optional: Parafilm the edges of the dish to minimize contamination.
9. If any mimic plates will be seeded with the study, make enough ECM-1T and ECM-2B solutions to coat the calculated number of wells to be seeded (100 μL /well), add DPBS 1x in the surrounding wells, and leave at 4°C until seeding day.

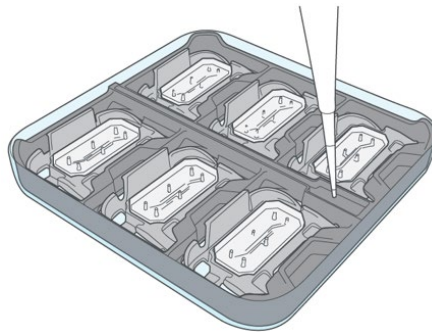

Figure 11: Fill central reservoir of Chip Cradle with 0.75 mL of DPBS

TITLE	DOCUMENT	VERSION
Brain-Chip R1 Culture Guideline	EG-185	Rev A
	DATE	PAGE
	11Mar2026	24 OF 71

Day 0: BMECs to Chip

Goals:

- Seed vascular cells in chips

Key Steps:

- Warm Emulate Brain-Chip Vascular Channel Medium
- Prepare Complete Vascular Channel Seeding Medium
- Warm Emulate Brain-Chip Brain Channel Medium
- Wash chips
- Thaw BMECs
- Adjust cell density
- Seed BMECs to bottom channel
- Seed a well plate
- Incubate chips (overnight) at 37°C

Required Materials:

- Emulate Brain-Chip Brain Channel Medium (at 37°C)
- Emulate Brain-Chip Vascular Channel Medium (at 37°C)
- DPBS 1x (at room temperature)
- Human Serum, Platelet Poor Human Plasma (PPP)
- Y-27632 (ROCK inhibitor)
- Serological pipettes
- Pipettes and filtered tips
- Aspirator and sterile tips
- 15 mL conical tubes
- Diluted trypan blue counting solution
- Hemocytometer
- 96-well plate
- 70% ethanol
- Brightfield Microscope

TITLE	DOCUMENT EG-185	VERSION Rev A
Brain-Chip R1 Culture Guideline	DATE 11Mar2026	PAGE 25 OF 71

Prepare Complete Vascular Channel Seeding Medium

Complete Vascular Channel Seeding Medium

Reagent	Conc. [Stock]	Conc. [Final]	Source	Cat. No.
Emulate Brain-Chip Vascular Channel Medium	-	-	FUJIFILM Cellular Dynamics, Inc.	RGT-BRVC-150
Human Serum (PPP)	100%	5%	Sigma	P2918
Y-27632 (ROCK Inhibitor)	10 mM	10 μ M	StemCell	72304

- Warm Emulate Brain-Chip Vascular Channel Medium for 1 hr at 37°C prior to starting any work. Maintain at 37°C.
- Add the Human Serum (PPP) when prepared to wash chips.
- Add ROCK inhibitor when prepared to begin thawing and seeding BMECs.
- Use the day of preparation.

Prepare Chips

1. Transfer ECM-coated chips from the fridge (4°C) to the incubator (37°C) to warm for at least 4 hours.
2. Warm an adequate volume of Emulate Brain-Chip Brain Channel Medium and Vascular Channel Medium for 1 hr.
 - a. **Note:** Calculate for 200 μ L of media per channel per chip plus extra for pipetting loss.
3. Add the Human Serum (PPP) to the Emulate Brain-Chip Vascular Channel Medium to make **Base Vascular Channel Seeding Medium** with a final concentration following the table above.
 - a. **Note:** Do not filter or mix the Human Serum (PPP) prior to adding to the medium.
4. Gently wash the bottom channel of each chip with 200 μ L of the warmed Base Vascular Channel Seeding Medium, aspirating the outflow.
5. Gently wash the top channel of each chip with 200 μ L of warmed Emulate Brain-Chip Brain Channel Medium, aspirating the outflow.
6. Aspirate any medium on the surface of the chip, leaving the medium in the channels.
7. Cover the 120 mm dish and place the chips in the BSC hood until the BMECs are ready for seeding.

Thaw BMECs

Prior to thawing, prepare the **Complete Vascular Channel Seeding Medium** (Base Vascular Channel Seeding Medium + ROCK inhibitor) and bring into the BSC. Place a sterile 15 mL conical tube into the BSC and label it “BMECs”. Add 1 mL of the Complete Vascular Channel Seeding Medium to the BMEC-labeled conical tube.

1. Retrieve the vial of BMECs from the liquid nitrogen tank and thaw them quickly in a 37°C water bath. Remove from the water bath when only a small ice chip is left (about 2.5 – 3 minutes) and bring to the BSC. Wipe down the outside of the vial with a premoistened 70% ethanol wipe and bring the vial into the BSC.

TITLE Brain-Chip R1 Culture Guideline	DOCUMENT EG-185	VERSION Rev A
	DATE 11Mar2026	PAGE 26 OF 71

2. Carefully remove the vial's lid. Holding the cryovial at an angle, slowly add 1 mL of the Complete Vascular Channel Seeding Medium directly into the vial. Let it rest for 30 seconds.
3. Slowly take up and transfer the cell solution from the vial to the "BMECs" conical tube with 1 mL of media. Hold the conical at an angle and slowly dispense the cell suspension at the media line.
4. Take up 1 mL of fresh complete media, add it to the cryovial rinsing the walls, then collect again and slowly add to the "BMECs" conical tube with the cell suspension.
5. At a slow but steady pace, continue to add Complete Vascular Channel Seeding media to the "BMECs" conical tube, holding the conical of cells at an angle and slowly dispensing the media at the fill line.
6. The final volume in the "BMECs" conical tube is brought up to 10 mL.
7. Allow the cells to rest for 2 minutes in the BSC.
 - a. Letting the cells rest for 2 minutes allows them time to adjust and enter equilibrium prior to centrifuging. This will help reduce clumping in the next steps.
8. Centrifuge the "BMECs" conical of cells at 300 x G for 3 minutes at room temperature.
9. Visually confirm a pellet. Carefully aspirate all the supernatant, leaving the cell pellet undisturbed.
 - a. **Note:** Aspirate holding the conical straight up and not at an angle, to minimally disturb the pellet.
10. Using a P1000 pipette, add 1 mL of the complete media to the conical tube, gently pipetting up and down to break up the cell pellet and create a uniform cell suspension.
11. BMECs are prone to clumping. To achieve single cells, you may need to pipette often to maintain a uniform cell suspension.
 - a. **Note:** Keep in mind that it is still important to avoid forming bubbles while pipetting or rupturing the cells by positioning the end of the pipette tip too close to the bottom of the conical tube.

Trypan Blue Cell Counting Solution

Reagent	Volume	Source	Cat. No.
Complete Vascular Channel Seeding Medium	40 µL	-	-
Trypan blue	5 µL	Sigma	<u>93595</u>

- Maintain at room temperature prior to use.
- Prepare fresh for each use.

Adjust Cell Density

BMECs seeded in the Brain-Chip R1 must be seeded at a density of 12.23×10^6 cells/mL. Accurate seeding density is important to ensure viable and functional cells within the Brain-Chip R1 for long-term culture.

1. After resuspending the pellet in 1 mL to homogenize the cell suspension, transfer 5 µL of the cell suspension to the trypan blue cell counting solution, generating a 1:10 dilution.

TITLE Brain-Chip R1 Culture Guideline	DOCUMENT EG-185	VERSION Rev A
	DATE 11Mar2026	PAGE 27 OF 71

2. Mix the trypan blue solution thoroughly and dispense 10 μL to the counting chambers of a manual hemocytometer.
3. Count the BMECs (at least 2 counts).
 - a. **Note:** While under the microscope, ensure that you have a single cell suspension. If you do not have a single cell suspension and/or frequent clumping, go back to the conical tube and pipette up and down more until you do and redo the count.
4. Calculate your two counts individually. If the counts are a $>10\%$ difference you will need to do a third count. If they are consistent, put the values into the seeding calculator and continue with seeding.
5. Bring the cell suspension volume up to 3 mL then centrifuge at 300 x G for 3 minutes.
6. Visually confirm the cell pellet. Aspirate the supernatant and resuspend the BMEC pellet with the calculated seeding volume to achieve a density of 12.23×10^6 cells/mL.

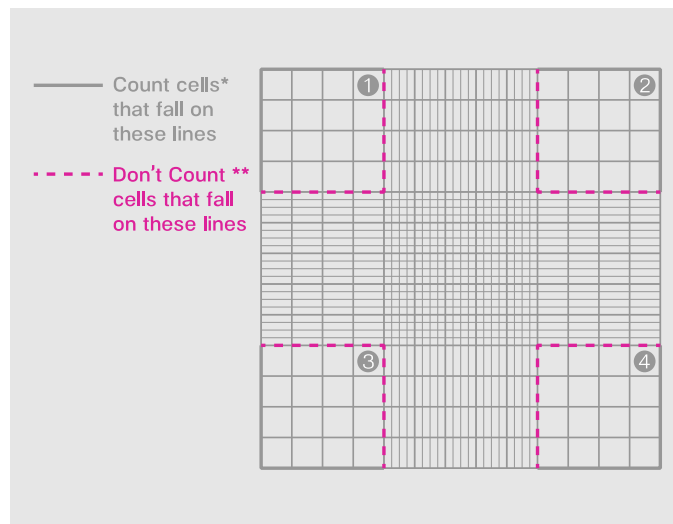

Figure 12. Schematic of a manual hemocytometer.

Cell Counting and Viability Assessment

1. Count both viable and non-viable cells in each quadrant of the hemocytometer.
Live Cell Count; Dead Cell Count; Total Cell Count
2. Calculate the percentage viability of the cell solution.
 $(\text{Live Cells}) \div (\text{Total Cells}) \times 100 = \% \text{ Viability}$
3. Calculate viable cell concentration. The dilution factor is 10 when prepared in the trypan blue cell counting solution above.
 $(\text{Live Cell Count} \times 10 \times 10^4) \div 4 = \text{Viable Cell Concentration (cells / mL)}$
4. Calculate viable cell yield.
 $(\text{Viable Cell Concentration}) \div (\text{Cell Suspension Volume}) = \text{Viable Cell Yield (cells)}$

TITLE	DOCUMENT EG-185	VERSION Rev A
Brain-Chip R1 Culture Guideline	DATE 11Mar2026	PAGE 28 OF 71

Dilute cells with warmed Complete Vascular Channel Seeding Medium to the required final cell density.

Seed BMECs to the Bottom Channel

Work with one chip at a time. After seeding the first chip, assess cell density within the channel through the microscope, adjusting the density of the cell suspension accordingly for the subsequent chips if necessary.

1. Bring the 120 mm dish containing the prepared chips to the BSC.
2. Avoiding contact with the inlet and outlet ports, carefully aspirate any excess medium droplets from the surface of one chip.
3. Gently agitate cell suspension before seeding each chip to ensure a homogeneous cell suspension.
4. Quickly and steadily pipette 18 μL of the cell suspension (at 12.23M cells/mL) into the bottom channel inlet port while aspirating the outflow fluid from the chip surface. Avoid direct contact with the outlet port.
5. Cover the dish and then transfer it to the microscope to check the seeding density within the chip.
 - a. **Note:** When seeding, work quickly as the chip(s) needs to be inverted as quickly as possible; the BMECs will stick to their surroundings and they need to attach to the underside of the membrane separating the top and bottom channels.
6. Optimal seeding density should form a uniform layer in the bottom channel.

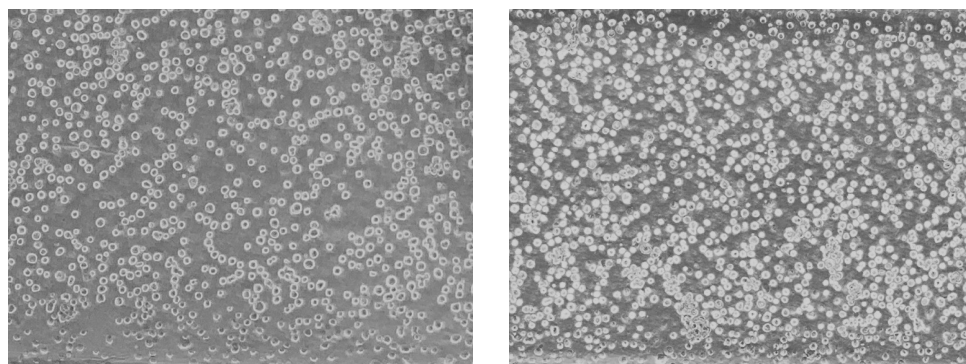

Figure 13. Left image depicts under-seeded BMECs, while the right image depicts optimal seeding density of BMECs.

7. If seeding density is not optimal, return the chip(s) to the BSC, and wash the channel with 200 μL of fresh complete medium twice. Do not aspirate the medium from the channel. Adjust cell density accordingly and repeat steps 3 through 5 until the correct density is achieved within the channel.
8. After confirming the correct cell density, seed the remaining chips in the chip cradle.
 - a. **Note:** Minimize the amount of time the cells are outside the incubator by seeding no more than 6 chips at a time, immediately placing the inverted chips in the incubator at 37°C after seeding each batch of 6.

TITLE	DOCUMENT EG-185	VERSION Rev A
Brain-Chip R1 Culture Guideline	DATE 11Mar2026	PAGE 29 OF 71

9. Once all chips in the chip cradle are seeded, close the lid of the square dish, and invert the whole dish, with the chips in the cradle inside, in a “hamburger style” flip (sideways rather than lengthwise of the chip).

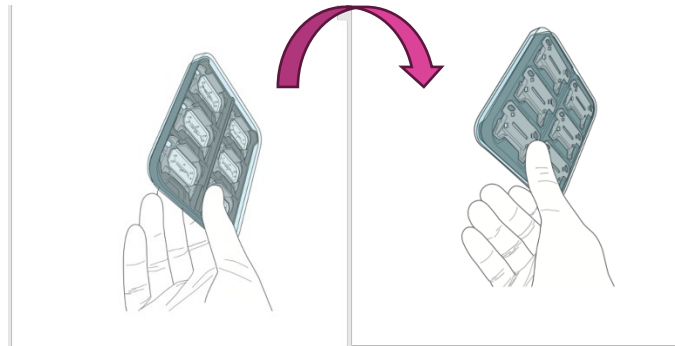

Figure 14. Image depicts the direction in how the chip cradle with chips should be inverted.

10. To prevent evaporation during incubation, fill the central reservoir with 0.75 mL of DPBS 1x.
 - a. **Note:** It is **highly recommended** to include an additional reservoir of DPBS 1x for added assurance against evaporation (e.g. using caps of 15 mL conical tubes).
 - i. While right-side up, remove one of the chips from the chip cradle (from one of the middle spaces).
 - ii. Replace the lid and invert the chip cradle and square dish with the open middle space.
 - iii. Fill the central reservoir with 0.75 mL of DPBS 1x and place a cap filled with approximately 1.5 mL of DPBS 1x into the open space.
 - iv. Place into the incubator (37°C) for overnight incubation.
 - v. Place the removed chip into a separate chip cradle and 120 mm square dish. Depending on how many chips are used for the experiment, place any other removed chips into this chip cradle, then invert it, and add DPBS 1x, as explained.
11. Place the inverted chips into an incubator at 37°C overnight; allow BMECs to attach (inverted) for at least **18 hours**.

Seed a Mimic Plate

It is recommended to seed any remaining BMECs into a plate as a control for cell quality. Cells are seeded onto a 96-well plate that is coated with ECM-2B, the same used for the bottom channels of the chips.

1. Further dilute the BMEC suspension with warm Complete Vascular Channel Seeding Medium to a final cell density of 6.4×10^5 cells/mL.
2. Add 100 μ L of the cell suspension to 3 separate wells of the 96-well plate.

TITLE	DOCUMENT	VERSION
Brain-Chip R1 Culture Guideline	EG-185	Rev A
	DATE	PAGE
	11Mar2026	30 OF 71

3. Mix each well to ensure an even suspension and then allow the cells to settle for 5 minutes. Inspect densities under the microscope.
4. Place the plate into the incubator; do not disturb the plate until the next day to allow for the BMECs to fully attach.
5. Change the media the next day.

TITLE	DOCUMENT EG-185	VERSION Rev A
Brain-Chip R1 Culture Guideline	DATE 11Mar2026	PAGE 31 OF 71

Day 1: BMEC Rest Day

Goals:

- Allow for monolayer stabilization

Key Steps:

- Replenish the medium for both the top channel and the bottom channel

Required Materials:

- Emulate Brain-Chip Vascular Channel Medium (at 37°C)
- Emulate Brain-Chip Brain Channel Medium (at 37°C)
- Human Serum (PPP)
- Serological pipettes
- Pipettes and filtered tips
- Aspirator and sterile tips
- 70% ethanol
- Brightfield Microscope

Warm & Prepare Media

1. Warm total volume needed of Emulate Brain-Chip Vascular Channel Medium for 1 hr at 37°C.
 - a. 100 µL per chip plus extra
2. Warm total volume needed of Emulate Brain-Chip Brain Channel Medium for 1 hr at 37°C.
 - a. 100 µL per chip plus extra

Complete Vascular Channel Medium

Reagent	Conc. [Stock]	Conc. [Final]	Source	Cat. No.
Emulate Brain-Chip Vascular Channel Media	-	-	FUJIFILM Cellular Dynamics, Inc.	RGT-BRVC-150
Human Serum (PPP)	100%	5%	Sigma	P2918

- Maintain at 37°C prior to use.
- Add the Human Serum (PPP) to the Emulate Brain-Chip Vascular Channel Medium when prepared to wash chips.
 - **Note:** Do not filter or mix the Human Serum (PPP) prior to adding to the medium.
- Prepare fresh for each use.

Wash Chips

1. Aspirate DPBS 1x from the central reservoir to prevent spillage before reverting the plate. Remove extra DPBS 1x caps and set aside, if added.
2. Revert the square dish with the chip cradle and chips inside.

TITLE	DOCUMENT EG-185	VERSION Rev A
Brain-Chip R1 Culture Guideline	DATE 11Mar2026	PAGE 32 OF 71

3. Very gently pipette 100 μ L of warmed Complete Vascular Channel Medium onto the inlet port of the bottom channel by forming droplets on the surface, rather than inserting the pipette tip into the port.
4. Allow the medium to flow through the channel via hydrostatic pressure. Aspirate the outflow from the opposite port to confirm that flow is established and to remove excess medium.
 - a. **Note:** If no flow is observed, insert the pipette tip gently into the port without dispensing any volume, and lightly wiggle the tip to dislodge any trapped bubbles. Do not force liquid into the channel.
 - b. **Note:** If media continues to *not flow*, take up 20 μ L of Complete Vascular Channel Medium with a P20 pipettor. Very carefully insert the pipette tip into the inlet port, establishing liquid-liquid contact before insertion. Very slowly, dispense the media and aspirate the outflow. Pipetting should be slow enough that the total volume would take 30-45 seconds to be dispensed.
5. Repeat above steps in the top channel with warmed Emulate Brain-Chip Brain Channel Medium.
6. Place additional droplets of respective media to cover all inlet and outlet ports to ensure that the channels do not dry out, BMECs receive nutrients, and bubbles do not affect cell attachment and culture.

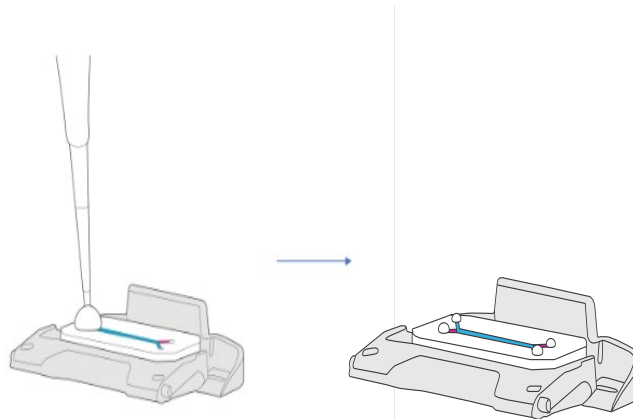

Figure 15: Chip with medium droplets covering the inlet and outlet ports of top and bottom channels.

7. Fill the central reservoir with 0.75 mL of DPBS 1x, replace any additional DPBS 1x reservoirs, and place cover onto the 120 mm square dish.
 - a. **Note:** Chips remain right-side up now.
8. Incubate chips overnight at 37°C.

TITLE	DOCUMENT	VERSION
Brain-Chip R1 Culture Guideline	EG-185	Rev A
	DATE	PAGE
	11Mar2026	33 OF 71

Day 2: Top Channel Seeding Day

Goals:

- Seed pericytes in chip
- Seed astrocytes, neurons, and microglia in chip

Key Steps:

- Prepare Complete Brain Channel Pericyte Seeding Medium
- Prepare Complete Vascular Channel Maintenance Medium
- Prepare chips
- Seed pericytes to top channel
- Seed a well plate
- Incubate chips (2-4 hours)
- Prepare Complete Brain Channel Seeding Medium
- Seed brain cells to top channel
- Seed a well plate
- Incubate chips (2 hours)
- Warm Emulate Brain-Chip Brain Channel Medium
- Wash chips
- Incubate chips (overnight at 37°C)

Required Materials:

- Emulate Brain-Chip Brain Channel Medium (at 37°C)
- Emulate Brain-Chip Vascular Channel Medium (at 37°C)
- B27
- Human Serum (PPP)
- Y-27632 (ROCK inhibitor)
- CNTF
- Trypan blue counting solution
- Hemocytometer
- 15 mL conical tubes
- Serological pipettes
- Pipettes and filtered tips
- Aspirator and sterile tips
- Ice bucket and ice
- 70% ethanol
- Brightfield Microscope
- DPBS 1x at room temperature

TITLE	DOCUMENT EG-185	VERSION Rev A
Brain-Chip R1 Culture Guideline	DATE 11Mar2026	PAGE 34 OF 71

Warm Media & Wash Chips

1. Warm volume needed of Emulate Brain-Chip Brain Channel Medium for 1 hr at 37°C.
2. Warm volume needed of Emulate Brain-Chip Vascular Channel Medium for 1 hr at 37°C.
3. Once warmed, bring chips to BSC.
4. Gravity wash 100 µL of Emulate Brain-Chip Brain Channel Medium in the top channels, aspirating any outflow and leaving the medium in the channel.
5. Aspirate any droplets on the surface of the chips.
6. Return chips to the incubator (37°C) until ready for seeding.
7. Make Complete Brain Channel Pericyte Seeding Medium.

Complete Brain Channel Pericyte Seeding Medium

Reagent	Conc. [Stock]	Conc. [Final]	Source	Cat. No.
Emulate Brain-Chip Brain Channel Medium	-	-	FUJIFILM Cellular Dynamics, Inc.	RGT-BRBC-150
Y-27632 (ROCK Inhibitor)	10 mM	10 µM	StemCell	72304

- Maintain at 37°C prior to use.
- Add ROCKi when prepared to thaw and seed pericytes to the chip(s).
- Prepare fresh for each use.

Thaw Pericytes

Pericytes must be thawed and counted for top channel seeding. Pericytes are adjusted to a density of 6.9×10^5 cells/mL before seeding into the top channel.

1. Set aside a 15 mL conical tube in the BSC labeled 'Pericytes'. Add 1 mL of warmed Complete Brain Channel Pericyte Seeding Medium to the tube.
2. Take your vial of cells from the liquid nitrogen tank and thaw it quickly by placing in a 37°C water bath. Remove from the water bath when only a small ice chip is left (about 2.5 – 3 minutes) and bring to the BSC. Wipe down the outside of the vial with a premoistened 70% ethanol wipe and bring the vial into the BSC.
3. Holding the cryovial at an angle, slowly add 1 mL of Complete Brain Channel Pericyte Seeding Medium directly into the vial. Transfer the cell solution (at the fill level) to the 15 mL conical tube labeled 'Pericytes' with the 1 mL of warmed complete seeding media already in it.
4. Wash the cryovial with 1 mL of warm seeding media, collect again, and slowly transfer it to the 'Pericytes' conical.
5. At a steady pace, continue to add warmed seeding media to the conical of cells until a final volume of 10 mL is achieved.

TITLE	DOCUMENT EG-185	VERSION Rev A
Brain-Chip R1 Culture Guideline	DATE 11Mar2026	PAGE 35 OF 71

6. Centrifuge the conical of cells at 300 x G for 3 minutes.
7. Visually confirm the cell pellet. Aspirate all the supernatant, leaving the cell pellet. Using a 1 mL pipette, add 1 mL of the warmed Complete Brain Channel Pericyte Seeding media to the conical, gently pipetting up and down to break up the cell pellet.

Trypan Blue Cell Counting Solution

Reagent	Volume	Source	Cat. No.
Complete Brain Channel Pericyte Seeding Medium	40 μ L	Recipe Above	-
Trypan blue	5 μ L	Sigma	<u>93595</u>

- Maintain at room temperature prior to use.
- Prepare fresh for each use.

Adjust Cell Density

Pericyte cells seeded in the Brain-Chip R1 must be seeded at a density of 6.9×10^5 cells/mL. Accurate seeding density is important to ensure viable and functional cells within the Brain-Chip R1 for long-term culture.

1. After resuspending the pellet in 1 mL to homogenize the cell suspension, transfer 5 μ L of the cell suspension to the trypan blue cell counting solution, generating a 1:10 dilution.
2. Mix the trypan blue solution thoroughly and dispense 10 μ L to the counting chambers of a manual hemocytometer.
3. Count the pericytes (at least 2 counts).
 - a. **Note:** While under the microscope, ensure that you have a single cell suspension. If you do not have a single cell suspension and/or frequent clumping, go back to the conical tube and pipette up and down more until you do and redo the count.
4. Calculate your two counts individually. If the counts differ by more than 10%, you will need to do a third count. If they are consistent, put the values into the seeding calculator and continue with seeding.
5. Bring the cell suspension volume up to 3 mL then centrifuge at 300 x G for 3 minutes.
6. Visually confirm the cell pellet. Aspirate the supernatant and resuspend the pericyte pellet with the calculated seeding volume to achieve a density of 6.9×10^5 cells/mL.

TITLE Brain-Chip R1 Culture Guideline	DOCUMENT EG-185	VERSION Rev A
	DATE 11Mar2026	PAGE 36 OF 71

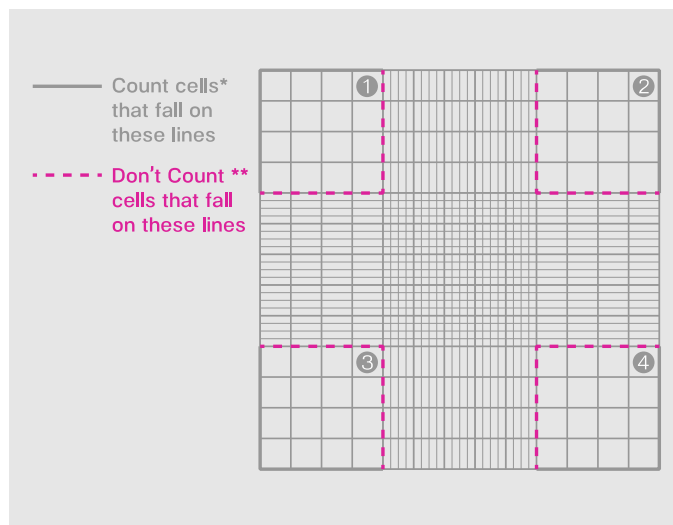

Figure 16. Schematic of a manual hemocytometer.

Cell Counting and Viability Assessment

- Count both viable and non-viable cells in each quadrant of the hemocytometer.
Live Cell Count; Dead Cell Count; Total Cell Count
- Calculate the percentage viability of the cell solution.
 $(\text{Live Cells}) \div (\text{Total Cells}) \times 100 = \% \text{ Viability}$
- Calculate viable cell concentration. The dilution factor is 10 when prepared in the trypan blue solution above.
 $(\text{Live Cell Count} \times 10 \times 10^4) \div 4 = \text{Viable Cell Concentration (cells / mL)}$
- Calculate viable cell yield.
 $(\text{Viable Cell Concentration}) \div (\text{Cell Suspension Volume}) = \text{Viable Cell Yield (cells)}$

Dilute cells with warm Complete Brain Channel Pericyte Seeding Medium to the required final cell density.

Seed Pericytes to Top Channel

Work with one chip at a time. After seeding the first chip, assess cell density within the channel through the microscope, adjusting the density of the cell suspension accordingly for the subsequent chips if necessary.

- Bring the 120 mm dish containing the prepared chips to the BSC.
- Avoiding contact with the inlet and outlet ports, carefully aspirate excess medium droplets from the surface of one chip.
- Very gently agitate cell suspension before seeding each chip to ensure a homogeneous cell suspension.

TITLE	DOCUMENT EG-185	VERSION Rev A
Brain-Chip R1 Culture Guideline	DATE 11Mar2026	PAGE 37 OF 71

4. Quickly and steadily pipette 28 μL of the pericyte cell suspension (at 6.9×10^5 cells/mL) into the top channel inlet port while aspirating the outflow fluid from the chip surface. Avoid direct contact with the outlet port.
5. Cover the dish and then transfer it to the microscope to check the seeding density within the chip.
 - a. **Note:** Pericyte density is 1:10 with BMECs. Pericyte seeding density will appear sparse.

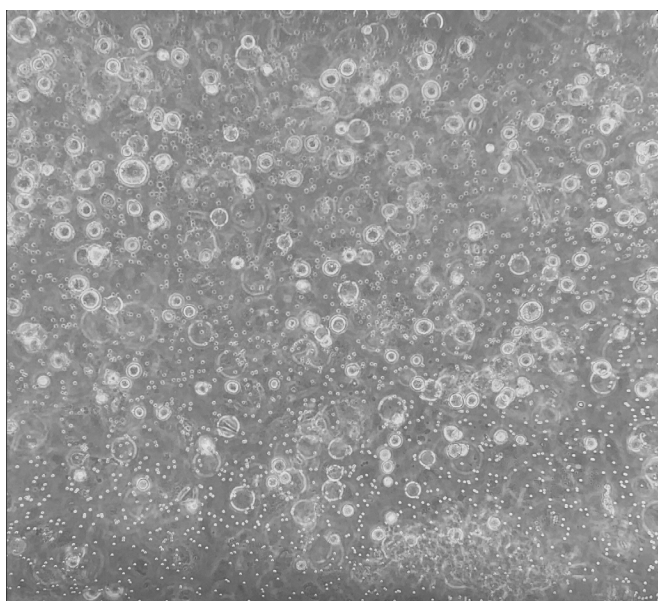

Figure 17. Image depicts initial pericyte seeding and optimal seeding density.

6. If seeding density is not optimal, return the chips to the BSC, and wash the channel with 200 μL of fresh medium twice. Do not aspirate the medium from the channel. Adjust cell density accordingly and repeat steps 3 through 5 until the correct density is achieved within the channel.
7. After confirming the correct cell density, seed cells in the remaining chips.
 - a. **Note:** To minimize the amount of time the chips are outside the incubator, seed no more than 6 chips at a time, immediately placing the chips in the incubator at 37°C after seeding each batch of 6.
8. Prepare Complete Vascular Channel Maintenance Medium. Once pericyte seeding is completed, add droplets of the complete vascular maintenance media to the inlet/outlet ports of the bottom channel for each chip.
 - a. **Note:** Do not allow bottom channel droplets to run to the top channel ports or the seeded pericytes may flow out of the chip.

TITLE	DOCUMENT	VERSION
Brain-Chip R1 Culture Guideline	EG-185	Rev A
	DATE	PAGE
	11Mar2026	38 OF 71

Complete Vascular Channel Maintenance Medium

Reagent	Conc. [Stock]	Conc. [Final]	Source	Cat. No.
Emulate Brain-Chip Vascular Channel Medium	-	-	FUJIFILM Cellular Dynamics, Inc.	RGT-BRVC-150
B27	50X	1X	Gibco	17504-044
Human Serum (PPP)	100%	2%	Sigma	P2918

- Maintain at 37°C prior to use.
 - If only B27 is added to the Emulate Brain-Chip Vascular Channel Medium, media can be stored at 4°C and must be used within 15 days of preparation.
 - Add the B27 and Human Serum (PPP) to the Emulate Brain-Chip Vascular Channel Medium when prepared to add droplets to chips.
 - **Note:** Do not filter or mix the Human Serum (PPP) prior to adding to the medium.
 - Media with Human Serum (PPP) must be prepared fresh for each use.
- To prevent evaporation during incubation, fill the central reservoir with 0.75 mL of DPBS 1x and place the cover onto the 120 mm square dish. If additional reservoirs of DPBS 1x were used, return them to the dish as well. The chips remain right-side up.
 - Place the chips in the incubator at 37°C for 2-4 hours or until cells have attached.

Seed a Mimic Plate

It is recommended to seed any remaining pericytes into a plate as a control for cell quality. Cells are seeded on a 96-well plate that was coated with the same ECM (ECM-1T) at the same time as the top channels of the chips on Day -1.

- Further dilute the pericyte suspension with warm Complete Brain Channel Pericyte Seeding Medium to a final cell density of 5.71×10^5 cells/mL.
- Add 100 μ L of the cell suspension to 3 separate wells of the 96-well plate.
- Mix each well to ensure an even suspension and then allow the cells to settle for 5 minutes on the microscope stage. Inspect densities under the microscope.
- In the incubator, disperse the cells evenly across the bottom of the culture wells by moving the plate in a figure-eight motion across the shelf at least 3 times while keeping the plate flat on the surface of the incubator. Once the cells are dispersed, do not disturb the plate until the next day to allow for cells to fully attach.
- Change the media the next day.

TITLE	DOCUMENT EG-185	VERSION Rev A
Brain-Chip R1 Culture Guideline	DATE 11Mar2026	PAGE 39 OF 71

Wash Chips

1. After pericyte incubation and confirming for cell attachment, gravity wash 100 μ L of warmed Emulate Brain-Chip Brain Channel Medium for the top channels of all the chips. This should cause medium to gently flow through the channel, spilling out of the outlets. Aspirate the outflow, careful not to aspirate the media from the channels.

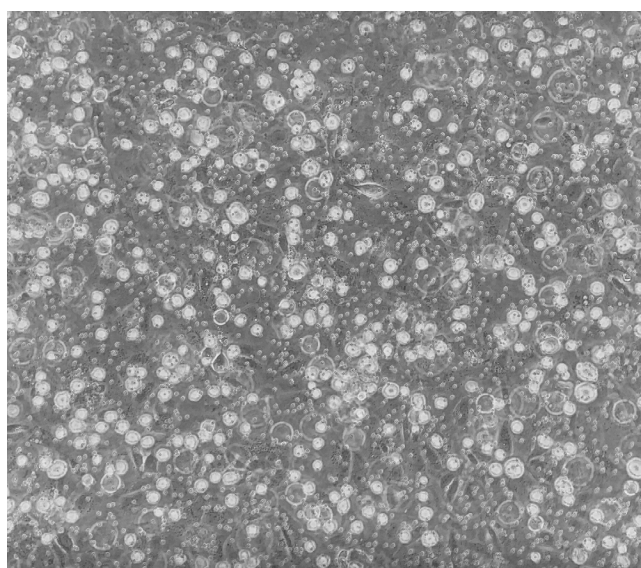

Figure 18. Image depicts pericyte attachment after 2 h.

2. If the media does not flow through the channel, very gently pipette a small amount of medium into the inlets, until a small droplet appears on the outlet, or until a bubble is ejected through the outlet.
3. Leave chips in 37°C until ready to seed the remaining top channel cells.

Prepare Complete Brain Channel Seeding Medium

Complete Brain Channel Seeding Medium

Reagent	Conc. [Stock]	Conc. [Final]	Source	Cat. No.
Emulate Brain-Chip Brain Channel Medium	-	-	FUJIFILM Cellular Dynamics, Inc.	RGT-BRBC-150
Recombinant Human CNTF	100 μ g/mL	10 ng/mL	PeptoTech	450-13-20UG

- Maintain at 37°C.

TITLE	DOCUMENT EG-185	VERSION Rev A
Brain-Chip R1 Culture Guideline	DATE 11Mar2026	PAGE 40 OF 71

- Add the CNTF when prepared to thaw and seed the astrocytes, GABANeurons, and microglia to the chip(s).
 - Prepare fresh for each use.
1. Warm Emulate Brain-Chip Brain Channel Medium at 37°C for 1 h prior to use.
 2. Add CNTF when prepared to thaw brain cell vials.
 3. Prepare 3 15 mL conical tubes labeled 'Astrocytes', 'Neurons', and 'Microglia' and place them in the BSC. Add 1 mL of warmed Complete Brain Channel Seeding Medium to each tube.

Thaw Astrocytes

Astrocytes are thawed and counted for top channel seeding. Astrocytes are seeded at a final density of 9.09×10^5 cells/mL. **Astrocytes are thawed slower than other cell types.** Slowly adding the media to the cells limits the amount of shock the cells experience as their environmental temperature and osmolarity change. Additionally, it allows the cells time to diffuse out of the DMSO.

1. Take the astrocyte vial from the liquid nitrogen tank and thaw it quickly by placing in a 37°C water bath. Remove from the water bath when only a small ice chip is left (about 2.5 – 3 minutes) and bring to the BSC. Wipe down the outside of the vial with a premoistened 70% ethanol wipe and bring the vial into the BSC.
2. Holding the cryovial at an angle, slowly add 1 mL of warmed Complete Brain Channel Seeding Medium directly into the vial.
3. Let it rest for 30 seconds.
4. Transfer the cell solution to the 'Astrocyte' conical with 1 mL of warmed media. Hold the conical at an angle and slowly dispense the cell suspension at the media line.
5. Take 1 mL of fresh, warmed seeding media, add it to the cryovial rinsing the walls in the process, and collect the rinse. Slowly add it to the 'Astrocyte' conical at the media line.
6. At a slow but steady pace, continue to add warmed seeding media to the 'Astrocyte' conical, holding the tube at an angle and continuing to move the pipette back as it is filling. The final cell suspension volume will be 10 mL.
7. Allow the cells to rest for 2 minutes.
8. Centrifuge the conical of cells at 250 x G for 2.5 minutes.
9. Visually confirm the cell pellet in the conical tube.
 - a. **Note:** If the pellet is not visually confirmed, centrifuge the cell suspension again.
10. Aspirate all the supernatant, leaving the cell pellet untouched.
 - a. **Note:** Hold the 'Astrocyte' tube vertically as you are aspirating the supernatant. Do not tilt the tube. This will minimally disturb the cell pellet.
11. Using a 1 mL pipette, add 300 μ L of the Complete Brain Channel Seeding media to the conical tube, gently pipetting up and down to break apart the Astrocyte pellet and resuspend the cells.
12. Set aside for counting.

Adjust Cell Density

TITLE	DOCUMENT	VERSION
Brain-Chip R1 Culture Guideline	EG-185	Rev A
	DATE	PAGE
	11Mar2026	41 OF 71

Astrocytes seeded in the Brain-Chip R1 must be seeded at a final density of 9.09×10^5 cells/mL. Accurate seeding density is important to ensure viable and functional cells within the Brain-Chip R1 for long-term culture.

TITLE	DOCUMENT EG-185	VERSION Rev A
Brain-Chip R1 Culture Guideline	DATE 11Mar2026	PAGE 42 OF 71

Trypan Blue Cell Counting Solution

Reagent	Volume	Source	Cat. No.
Complete Brain Channel Seeding Medium	40 μ L	Recipe Above	-
Trypan blue	5 μ L	Sigma	93595

- After resuspending the pellet in 300 μ L to homogenize the cell suspension, transfer 5 μ L of the cell suspension to the trypan blue cell counting solution, generating a 1:10 dilution.
- Mix the trypan blue solution thoroughly and dispense 10 μ L to the counting chambers of a manual hemocytometer.
- Count the astrocytes (at least 2 counts).
 - Note:** While under the microscope, ensure that you have a single cell suspension. If you do not have a single cell suspension and/or frequent clumping, go back to the conical tube and pipette up and down more until you do and redo the count.
- Calculate your two counts individually. If the counts differ by more than 10%, you will need to do a third count. If they are consistent, put the values into the seeding calculator and continue with seeding.
- Dilute cells with warm Complete Brain Channel Seeding Medium to a cell density that when combined 1:1:1 with the GABANeurons and Microglia, will yield a final density of 9.09×10^5 cells/mL.

Thaw GABANeurons

GABANeurons are thawed and counted for top channel seeding. Neurons are seeded at a final density of 2.73×10^6 cells/mL.

- Take your GABANeuron vial from the liquid nitrogen tank and thaw it quickly by placing it in a 37°C water bath. Remove from the water bath when only a small ice chip is left (about 2.5 – 3 minutes) and bring to the BSC. Wipe down the outside of the vial with a premoistened 70% ethanol wipe and bring the vial into the BSC.
- Holding the cryovial at an angle, slowly add 1 mL of warmed Complete Brain Channel Seeding Medium into the vial.
- Transfer the cell solution to the 'Neuron' conical that already has 1 mL of warmed seeding media. Hold the conical at an angle and slowly dispense the cells in at the media line.
- Take 1 mL of fresh, warmed seeding media, add it to the cryovial rinsing the walls in the process, and collect the rinse. Slowly add it to the 'Neuron' conical at the media line.
- At a steady pace, continue to add seeding media to the conical of cells, holding the tube at an angle, and continuing to move the pipette back as you are filling. The final volume should be 10 mL.
- Centrifuge the conical of cells at 250 x G for 2.5 minutes.
- Visually confirm the cell pellet in the conical tube.
 - Note:** If the pellet is not visually confirmed, centrifuge the cell suspension again.
- Aspirate all the supernatant, leaving the cell pellet untouched.
 - Note:** Hold the 'Neuron' tube vertically as you are aspirating the supernatant. Do not tilt the tube. This will minimally disturb the cell pellet.

TITLE	DOCUMENT EG-185	VERSION Rev A
Brain-Chip R1 Culture Guideline	DATE 11Mar2026	PAGE 43 OF 71

9. Using a 1 mL pipette, add 300 μ L of the complete seeding media to the conical, gently pipetting up and down to break apart the Neuron pellet and resuspend the cells.
10. Set aside for counting.

Adjust Cell Density

GABANeurons seeded in the Brain-Chip R1 must be seeded at a final density of 2.73×10^6 cells/mL. Accurate seeding density is important to ensure viable and functional cells within the Brain-Chip R1 for long-term culture.

Trypan Blue Cell Counting Solution

Reagent	Volume	Source	Cat. No.
Complete Brain Channel Seeding Medium	40 μ L	Recipe Above	-
Trypan blue	5 μ L	Sigma	93595

1. After resuspending the pellet in 300 μ L of seeding media to homogenize the cell suspension, transfer 5 μ L of the cell suspension to the trypan blue cell counting solution, generating a 1:10 dilution.
2. Mix the trypan blue solution thoroughly and dispense 10 μ L to the counting chambers of a manual hemocytometer.
3. Count the GABANeurons (at least 2 counts).
 - a. **Note:** While under the microscope ensure that you have a single cell suspension. If you do not have a single cell suspension and/or frequent clumping, go back to the conical tube and pipette up and down more until you do and redo the count.
4. Calculate your two counts individually. If the counts differ by more than 10%, you will need to do a third count. If they are consistent, put the values into the seeding calculator and continue with seeding.
5. Dilute cells with warm Complete Brain Channel Seeding Medium to a cell density that when combined 1:1:1 with the Astrocytes and Microglia, will yield a final density of 2.73×10^6 cells/mL.

Thaw Microglia

Microglia are thawed and counted for top channel seeding. Microglia are seeded at a final density of 6.49×10^5 cells/mL. **Microglia are thawed slower than other cell types.** Slowly adding the media to the cells limits the amount of shock the cells experience as their environmental temperature and osmolarity change. Additionally, it allows the cells time to diffuse out of the DMSO.

The microglia thawing guideline is deliberately slowed so they can be seeded at a resting state. The slow addition of media allows them to avoid environmental shock and the osmolarity changes, as well as to not become reactive in the process.

1. Take your microglia vial from the liquid nitrogen tank and thaw it by placing it in a 37°C bead bath. Ensure that the frozen vial is submerged. Leave it in the bead bath for 8 minutes.

TITLE	DOCUMENT EG-185	VERSION Rev A
Brain-Chip R1 Culture Guideline	DATE 11Mar2026	PAGE 44 OF 71

2. After the 8 minutes, wipe down the outside of the vial with a premoistened 70% ethanol wipe and bring into the BSC.
3. Holding the cryovial at an angle, slowly add 1 mL of warmed Complete Brain Channel Seeding Medium directly into the vial. Let it rest for 60 seconds.
4. Transfer the cell solution to the 'Microglia' conical tube that already has 1 mL of warmed seeding media. Hold the conical at an angle and slowly dispense the cells in at the media line.
5. Take 1 mL of fresh, warmed seeding media and rinse the inside of the cryovial to collect any remaining cells. Slowly add this rinse to the 'Microglia' tube cell suspension at the media line.
6. Working in 1 minute intervals, slowly add 1 mL of seeding media to the cell suspension in the tube, until you have reached a final volume of 10 mL. To avoid cells clumping at the bottom, gentle mixing with a P1000 pipette may be performed, holding the tube at an angle and gently pipetting up and down.
 - a. **Note:** The key to this thawing guideline is to slowly add media to the cell suspension, where every addition of 1 mL of media takes 50-60 seconds. It should take ~10 minutes to add the total volume of media.
7. Centrifuge the conical of cells at 300 x G for 3 minutes.
8. Visually confirm the cell pellet in the conical tube.
 - a. **Note:** If the pellet is not visually confirmed, centrifuge the cell suspension again.
9. Aspirate all the supernatant, leaving the cell pellet untouched.
 - a. **Note:** Hold the 'Microglia' tube vertically as you are aspirating the supernatant. Do not tilt the tube. This will minimally disturb the cell pellet.
10. Using a 1 mL pipette, add 300 μ L of the complete seeding media to the conical, gently pipetting up and down to break apart the Microglia pellet and resuspend the cells.
11. Set aside for counting.

Adjust Cell Density

Microglia seeded in the Brain-Chip R1 must be seeded at a final density of 6.49×10^5 cells/mL. Accurate seeding density is important to ensure viable and functional cells within the Brain-Chip R1 for long-term culture.

Trypan Blue Cell Counting Solution

Reagent	Volume	Source	Cat. No.
Complete Brain Channel Seeding Medium	40 μ L	Recipe Above	-
Trypan blue	5 μ L	Sigma	<u>93595</u>

1. After resuspending the pellet in 300 μ L of seeding media to homogenize the cell suspension, transfer 5 μ L of the cell suspension to the trypan blue cell counting solution, generating a 1:10 dilution.
2. Mix the trypan blue solution thoroughly and dispense 10 μ L to the counting chambers of a manual hemocytometer.
3. Count the microglia (at least 2 counts).

TITLE	DOCUMENT EG-185	VERSION Rev A
Brain-Chip R1 Culture Guideline	DATE 11Mar2026	PAGE 45 OF 71

- a. **Note:** While under the microscope, ensure that you have a single cell suspension. If you do not have a single cell suspension and/or frequent clumping, go back to the conical tube and pipette up and down more until you do and redo the count.
4. Calculate your two counts individually. If the counts differ by more than 10%, you will need to do a third count. If they are consistent, put the values into the seeding calculator and continue with seeding.
5. Dilute cells with warm Complete Brain Channel Seeding Medium to a cell density that when combined 1:1:1 with the Astrocytes and GABANeurons, will yield a final density of 6.49×10^5 cells/mL.

Example Top Channel Seeding Calculations

The top channel cells are seeded together in a mixed suspension. By combining volumes in a 1:1:1 ratio, we are able to achieve their final densities. Accurate seeding density is important to ensure viable and functional cells within the Brain-Chip R1 for long-term culture.

Cell Type	Adjusted Density	Final Density
Astrocytes	2.73×10^6 cells/mL	9.09×10^5 cells/mL
GABANeurons	8.19×10^6 cells/mL	2.73×10^6 cells/mL
Microglia	1.95×10^6 cells/mL	6.49×10^5 cells/mL

Example Calculations

Cell Type	Calculated Vial Density (cells/mL)	Suspension Volume (mL)	Total Cells	Adjusted Density (cells/mL)	Final Resuspension Volume (mL)
Astrocytes	2.93×10^6	0.300	8.78×10^5	2.73×10^6	0.322
GABANeurons	1.58×10^7	0.310	4.89×10^6	8.19×10^6	0.597
Microglia	3.61×10^6	0.307	1.11×10^6	1.95×10^6	0.570

Of the three cell types, for this example, the astrocytes have the lowest final resuspension volume. Using the lowest final resuspension volume calculated, the three cell types can be combined 1:1:1 in volume to achieve their final densities.

= 0.322 mL Astrocyte final resuspension volume + 0.322 mL GABANeuron final resuspension volume + 0.322 mL Microglia final resuspension volume

= 0.966 mL Brain Channel Cell Suspension Volume

Seed Brain Cell Suspension to Top Channel

Work with one chip at a time. After seeding the first chip, assess cell density within the channel through the microscope, adjusting the density of the cell suspension for the next chips if necessary.

1. Bring a 120 mm square dish containing the prepared, already washed chips to the BSC.

TITLE	DOCUMENT EG-185	VERSION Rev A
Brain-Chip R1 Culture Guideline	DATE 11Mar2026	PAGE 46 OF 71

2. Avoiding contact with the ports, carefully aspirate excess medium droplets from the surface of one chip.
3. Prepare final brain cell suspension by mixing the cells from the vials to achieve their final densities.
4. Gently agitate the brain cell suspension before seeding each chip to ensure a homogeneous brain cell suspension.
5. Pipette 28 μL of the brain cell suspension into the top channel of one chip first via the inlet port, while aspirating the outflow. Be careful not to directly aspirate from the outlet port.
6. Cover the dish and transfer it to the microscope to check the seeding density within the chip.

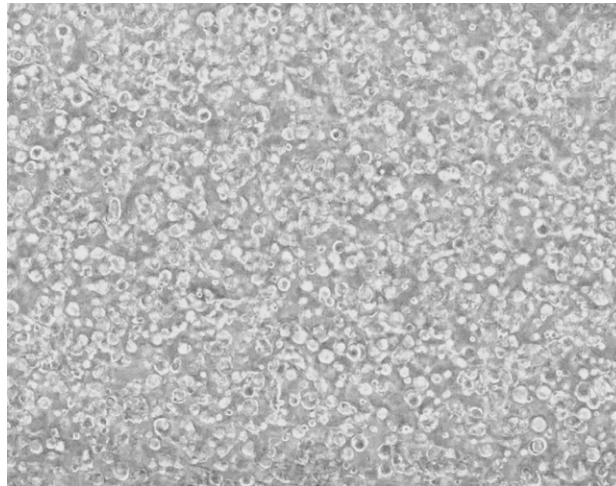

Figure 19. Image depicts initial mixed brain cell seeding and optimal seeding density.

7. If seeding density is not optimal, return the chip to the BSC and wash the channel twice with 200 μL of fresh Complete Brain Channel Seeding Medium. Do not aspirate the medium from the channel prior to washing. Adjust the volume of the cell suspension as needed to obtain correct seeding density and repeat steps 5 through 6 until the correct density is achieved within the channel.
8. After confirming the correct cell density, seed the remaining chips in the Chip Cradle.
 - a. **Note:** Minimize the amount of time the cells are outside the incubator by seeding no more than 6 chips at a time, immediately placing the chips in the incubator at 37°C after seeding.
9. Proceed with the remaining chips until all have been seeded.
10. Add droplets of warmed Complete Vascular Channel Maintenance Medium to the inlet/outlet ports of the bottom channel for each chip.
 - a. **Note:** Do not allow bottom channel droplets to run to the top channel ports or the seeded brain cells may flow out of the chip.
11. To prevent evaporation during incubation, fill the central reservoir with 0.75 mL of DPBS 1x and place the cover onto the 120 mm square dish. If additional reservoirs of DPBS 1x were used, return them to the dish as well. The chips remain right-side up.
12. Incubate at 37°C for 2 hours or until the brain cells in the top channel have attached.

TITLE	DOCUMENT EG-185	VERSION Rev A
Brain-Chip R1 Culture Guideline	DATE 11Mar2026	PAGE 47 OF 71

Seed a Mimic Plate

It is recommended to seed any remaining brain cell suspension into a plate as a control for cell quality. Cells are seeded on a 96-well plate that was coated with the same ECM (ECM-1T) at the same time as the top channels of the chips on Day -1.

1. Further dilute the brain cell suspension with warmed Complete Brain Channel Seeding Medium so there is enough volume to seed the number of wells you want (100 μ L/well).
2. Add 100 μ L of the brain cell suspension to the selected wells of the 96-well plate.
3. Mix each well to ensure an even suspension and then allow the cells to settle for 5 minutes on the microscope stage. Inspect densities under the microscope.
4. In the incubator, disperse the cells evenly across the bottom of the culture wells by moving the plate in a figure-eight motion across the shelf at least 3 times while keeping the plate flat on the surface of the incubator. Once the cells are dispersed, do not disturb the plate until the next day to allow for cells to fully attach.
5. Change the media the next day.
 - a. **Note:** It is recommended to seed the excess brain cell suspension in wells with and without attached pericytes. This way there are conditions to monitor all top channel cell interactions and morphology and the brain cell suspension independently.

Add Tips to Chips for Overnight Incubation & Media Wash Out

1. Warm new aliquots of Complete Vascular Channel Maintenance Medium and Emulate Brain-Chip Brain Channel Medium (50 μ L per chip plus extra) for 1 h at 37°C.
2. Visually confirm that top channel brain cells have attached.

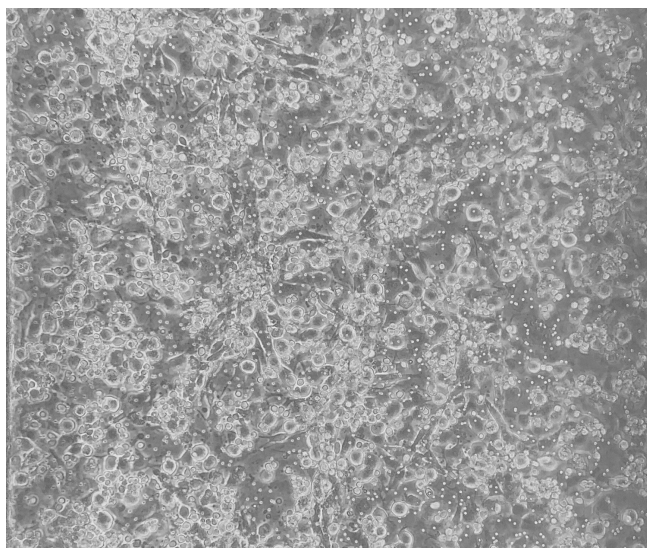

Figure 20. Image depicts mixed brain cell attachment after 2 h.

TITLE	DOCUMENT EG-185	VERSION Rev A
Brain-Chip R1 Culture Guideline	DATE 11Mar2026	PAGE 48 OF 71

3. Insert a P200 pipette tip with 50 μ L of Emulate Brain-Chip Brain Channel Medium into the top channel inlet port.
 - a. **Note:** Carefully dispense a small volume of the 50 μ L so a droplet forms at the tip of the pipette tip, then insert the tip into the inlet port. Then, eject the tip from the pipette without lifting the pipette plunger. Adding tips in this manner will maintain the liquid-liquid contact of the chip channel with the media in the pipette tip, as well as minimally disturb the channel contents.
4. A small volume of media will start to flow out of the top channel at the outlet port; insert an empty P200 pipette tip into the outlet port.
5. Repeat this process but with Complete Vascular Channel Maintenance Medium for the bottom channel for each chip.
6. Aspirate any excess media found on the chips surrounding the inlet/outlet ports plugged with the P200 pipette tips. (See Figure 21)

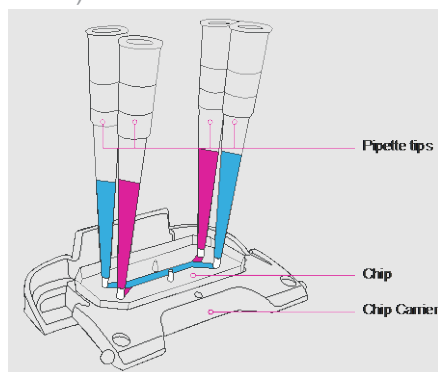

Figure 21: Chip with filtered tips inserted into ports with respective media.

7. Aspirate the DPBS 1x in the chip cradle reservoir and discard any additional DPBS 1x reservoirs from the chip cradle and 120 mm square dish.
8. Return chips with the inserted pipette tips to the incubator (37°C, 5% CO₂) for overnight incubation.
9. Cells are maintained in static culture in the chips overnight until connection day, where chips are connected to Pods and then inserted into the Zoë to initiate experimental flow.

TITLE	DOCUMENT	VERSION
Brain-Chip R1 Culture Guideline	EG-185	Rev A
	DATE	PAGE
	11Mar2026	49 OF 71

Day 3: Chips to Pods and Pods to Zoë

Goals:

- De-gas and equilibrate media
- Prime Pods
- Connect chips to Pods
- Connect Pods to Zoë

Key Steps:

- Gas equilibration of media
- Prime Pods
- Wash chips
- Connect chips to Pods
- Connect Pods to Zoë
- Run Regulate Cycle (2x)
- Begin experimental flow

Required Materials:

- Installed and qualified Zoë
- Prepared chips
- Pods (sterile)—1 per chip
- Tray—1 per 6 chips
- Steriflip filtration unit: PVDF filter 0.45 μm (sterile), 1 for each medium
- Vacuum source (minimum -70 kPa)
- Emulate Brain-Chip Brain Channel Medium
- Emulate Brain-Chip Vascular Channel Medium
- B27
- Human Serum (PPP)
- Serological pipettes
- Pipettors and filtered tips
- 37°C water or bead bath
- 70% ethanol

TITLE	DOCUMENT EG-185	VERSION Rev A
Brain-Chip R1 Culture Guideline	DATE 11Mar2026	PAGE 50 OF 71

Prepare & Warm Media

1. Warm a sufficient volume of Emulate Brain-Chip Brain Channel Medium for chip washing and connection (3 mL per chip) for 1 h at 37°C.
2. Prepare Base Vascular Channel Medium and warm a sufficient volume for chip washing and connection (3 mL per chip) for 1 h at 37°C.

Base Vascular Channel Maintenance Medium

Reagent	Conc. [Stock]	Conc. [Final]	Source	Cat. No.
Emulate Brain-Chip Vascular Channel Medium	-	-	FUJIFILM Cellular Dynamics, Inc.	RGT-BRVC-150
B27	50X	1X	Gibco	17504-044

- If only B27 is added to the Emulate Brain-Chip Vascular Channel Medium, media can be stored at 4°C and must be used within 15 days of preparation.

Gas Equilibration of Media

The media equilibration step is important for the success of Organ-Chip culture. Omission of this step will cause the eventual formation of bubbles in the chip, the Pod, or both, which will in turn cause irregular flow and negatively impact cell viability. Minimize the time media is outside of a warmed environment (such as an incubator or bath) to no more than 10 minutes, as gas equilibrium can become compromised when media is allowed to cool.

1. Place at least 3 mL of Emulate Brain-Chip Brain Channel Medium for each chip in a 50-mL conical tube.
2. Place at least 3 mL of Base Vascular Channel Maintenance Medium for each chip in a separate 50 mL conical tube.
3. Warm both 50-mL conical tubes of media at 37°C in a water or bead bath for at least 1 hour.
4. After 1 h of warming, connect each 50-mL tube containing each warmed medium to a Steriflip unit.
 - a. Attach each conical tube containing warmed medium to a Steriflip unit.
 - b. With the unit "right-side-up" (medium in the bottom conical tube), place the Steriflip-connected tubes back into the 37°C water or bead bath.
 - c. Connect and apply vacuum for at least 10 seconds.
 - d. Invert the Steriflip-connected tubes, and check that the medium begins to pass from the top conical tube to the lower tube.
 - **Note:** The vacuum source must operate at a minimum of -70 kPa. At this correct pressure, it should take about 2 seconds for every 10 mL of medium to flow through the filter. If it takes longer, stop and see the troubleshooting guideline, as this indicates the medium will not be equilibrated properly.
 - e. Leave the filtered medium under vacuum for 5 minutes.
5. Shut off the vacuum and remove the vacuum tubing from the Steriflip units.
6. Wipe down the Steriflip-connected tubes with 70% ethanol and bring into the BSC.
7. Separate the conical tubes containing media from the Steriflip unit and put on caps.

TITLE Brain-Chip R1 Culture Guideline	DOCUMENT EG-185	VERSION Rev A
	DATE 11Mar2026	PAGE 51 OF 71

8. Place the conical tube containing Emulate Brain-Chip Brain Channel media into an incubator with the cap loose or in a 37°C bead bath with the cap screwed on.
9. Add Human Serum (PPP) to the Base Vascular Channel Maintenance Medium to make Complete Vascular Channel Maintenance Medium.

Complete Vascular Channel Maintenance Medium

Reagent	Conc. [Stock]	Conc. [Final]	Source	Cat. No.
Base Vascular Channel Maintenance Medium	-	-	Recipe above	
Human Serum (PPP)	100%	2%	Sigma	P2918

- Do not filter or mix the Human Serum (PPP) prior to adding to the medium.
- Human Serum (PPP) is added after gas equilibration.
- Media with Human Serum (PPP) must be prepared fresh for each use.

10. Place the conical tube containing the Complete Vascular Channel Maintenance Medium into an incubator with the cap loose or in a 37°C bead-bath with the cap screwed on.

Note: Gas equilibration is completed when chips are ready to be washed and/or Pods are ready to be primed for connection. Gas Equilibration **cannot** be prepared ahead of time.

As noted above, minimize the time media is outside of the incubator during Pod preparation to maintain temperature. This is an important step to ensure the success of the experiment.

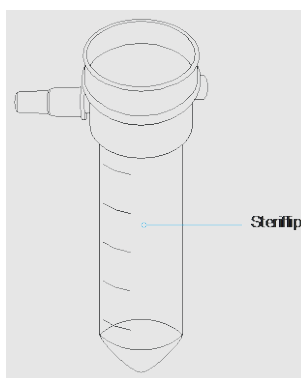

Figure 22. Schematic of a Steriflip

TITLE Brain-Chip R1 Culture Guideline	DOCUMENT EG-185	VERSION Rev A
	DATE 11Mar2026	PAGE 52 OF 71

Prime Pods

1. Sanitize the exterior of the Pod packaging and trays with 70% ethanol, wipe them down, and transfer them to the BSC.
2. Open the Pod package and place the Pods into the trays. Orient the Pods with the reservoirs toward the back of the tray.

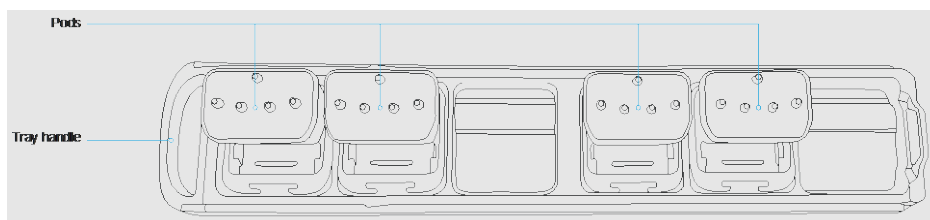

Figure 23. Diagram of Pod set-up on tray.

3. Pipette 2 mL of pre-equilibrated, warm media to each inlet reservoir. In the top channel inlet reservoir, add Emulate Brain-Chip Brain Channel Medium; in the bottom channel inlet reservoir, add Complete Vascular Channel Maintenance Medium.
4. Pipette 300 μ L of pre-equilibrated, warm respective medias into each top and bottom outlet reservoirs, directly over each outlet via.

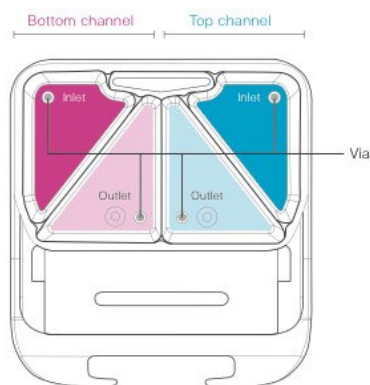

Figure 24. Overhead view inside of a Pod, depicting the bottom and top channel inlets and outlets.

5. Bring trays containing Pods to the incubator and slide them completely into Zoë with the tray handle facing outward.
 - a. **Note:** Zoë should be set to 'Chip-R1' settings on the display screen.

TITLE	DOCUMENT EG-185	VERSION Rev A
Brain-Chip R1 Culture Guideline	DATE 11Mar2026	PAGE 53 OF 71

6. Run the Prime Cycle on Zoë.
 - a. Using the Dial, highlight “Prime” on the Zoë UI
 - b. Press the Dial button to select Prime Cycle
 - c. Rotate the Dial clockwise to highlight “Confirm” and press the Dial button to initiate the Prime Cycle. A progress bar will appear showing the status of the Prime Cycle
 - d. Zoë will display “Prime Cycle Successful” after successfully completing the Prime Cycle. Press Accept to return to the Home view.

Note: After initiating a Prime Cycle, there will be an audible sound as Zoë engages the Pods. You can check the Prime Cycle status by referring to the progress bar.

7. Close the incubator door and allow Zoë to prime the Pods; this process takes approximately 1 minute.
 - a. **Note:** When the status bar reads “Ready,” the Prime Cycle is complete.
8. Remove the tray from the Zoë and bring into the BSC.
 - a. Verify that the Pods were successfully primed.
 - b. Inspect each Pod through the window—look for the presence of small droplets at all four fluidic ports. Droplets will vary in size from a small meniscus to larger droplets; often, droplets on the outlet ports will be larger.
 - If any Pod does not show droplets, re-run the Prime Cycle on those Pods.
 - If any media dripped onto the tray (this may occur more often by the outlet ports), clean the tray with a wipe sprayed with 70% ethanol.
9. Once it is confirmed that all Pod ports are wet with droplets, put the tray of Pods to the side of the BSC if ready for immediate connection, otherwise, return them to the incubator to stay warm.

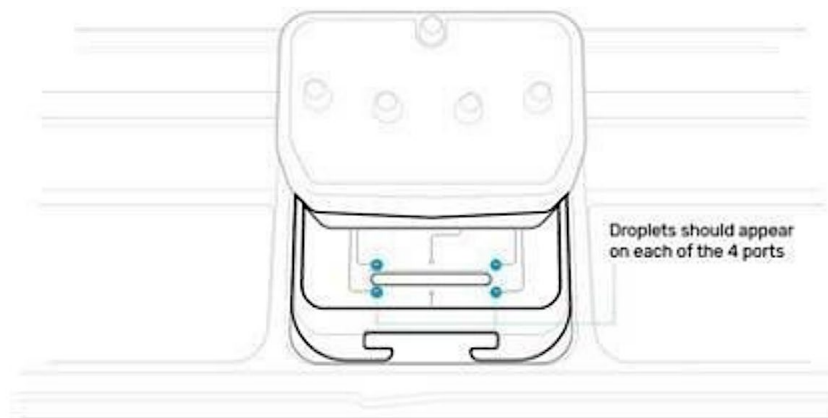

Figure 25. Diagram of a primed Pod with droplets shown in blue on each of the four ports.

TITLE	DOCUMENT	VERSION
Brain-Chip R1 Culture Guideline	EG-185	Rev A
	DATE	PAGE
	11Mar2026	54 OF 71

Wash Chips

1. Transfer the seeded chips in their 120 mm dish from the incubator to the BSC.
2. Remove the pipette tips from the chip top and bottom inlet and outlet ports.
3. Very gently and slowly wash the top channel of each chip (50 μ L) with warm, equilibrated Emulate Brain-Chip Brain Channel Medium to remove any possible bubbles in the channel.
4. Place small droplets of warm, equilibrated Emulate Brain-Chip Brain Channel Medium on each top inlet and outlet port of every chip.
 - a. **Note:** The droplet needs to be small and does not touch the bottom channel ports in any way.
5. Very gently and slowly wash the bottom channel of each chip (20 μ L) with warm, equilibrated Complete Vascular Channel Maintenance Medium to remove any possible bubbles in the channel.
6. Place small droplets of warm, equilibrated Complete Vascular Channel Maintenance Medium on each bottom inlet and outlet port of every chip.
 - a. **Note:** The droplet needs to be small and does not touch the top channel droplets/ports in any way.
7. Maintain the washed chips in the incubator until ready to connect to the Pods or proceed to connection right away in the BSC.

TITLE	DOCUMENT	VERSION
Brain-Chip R1 Culture Guideline	EG-185	Rev A
	DATE	PAGE
	11Mar2026	55 OF 71

Chips to Pods

1. Holding one chip in its chip carrier in the dominant hand and one Pod in the non-dominant hand, slide the chip carrier into the tracks on the underside of the Pod until the chip carrier has seated fully.
2. Place thumb on the chip carrier tab and gently, but firmly, press the tab in and up to engage the tab of the chip carrier with the Pod.
3. Aspirate any excess medium on the chip surface from the Pod window.
 - a. **Note:** This is a crucial step as media can easily fall into the recess of the Chip-R1 gasket during connection or at any point when leaving droplets over the ports (i.e., during ECM coating). DO NOT drag the aspirator tip across the top of the chip as this can cause scratches on the top layer. Instead, aspirate against the corners and edges of the chip gasket window.

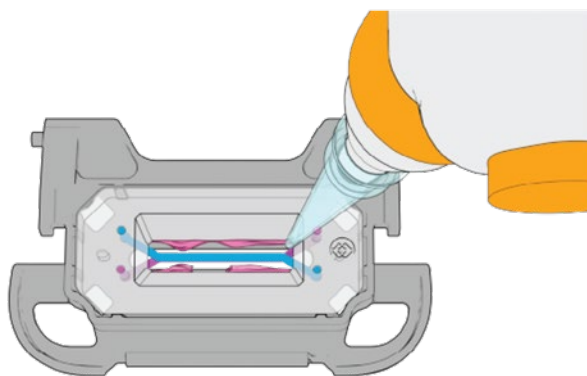

Figure 26. Diagram showing how to aspirate excess media from the gasket window without making contact with it.

4. Wipe the tray with a premoistened wipe with 70% ethanol and the underside of the Pod-Chip unit.
5. Place the Pod with the connected chip back onto the wiped tray.
6. Repeat steps 1 through 5 for each Pod and chip carrier.
7. Confirm that there is sufficient media in each Pod inlet and outlet reservoir.
8. Using a 200 μ L pipette, perform a via wash on each Pod inlet and outlet reservoir:
 - a. Using media within the Pod reservoir, pipette 200 μ L of media directly over the top of the via to dislodge any bubbles that may be present.
 - b. Repeat this wash step for each of the four Pod reservoirs.
9. Secure Pod lids.

TITLE	DOCUMENT	VERSION
Brain-Chip R1 Culture Guideline	EG-185	Rev A
	DATE	PAGE
	11Mar2026	56 OF 71

Pods to Zoë

1. Place trays that are holding Pods and chips immediately into Zoë to prevent media from cooling and losing its gas equilibration.
 - a. **Note:** Trays slide completely into Zoë with the tray handle facing outward.
2. Program the appropriate Organ-Chip culture conditions on Zoë. These conditions will start as soon as the Regulate Cycle is complete.
3. Zoë should be set to 'Chip-R1' on the display screen. Set top channel flow rate to 20 μ L/h and bottom channel flow rate to 20 μ L/h.
4. Run Regulate Cycle.
 - a. Using the Dial, highlight "Regulate" on the Zoë UI.
 - b. Press the Dial Button to display the "Start Regulate" view and ensure the correct Chip Type is displayed on screen.
 - c. Rotate the Dial clockwise to highlight "Confirm" and press the Dial Button to initiate the Regulate Cycle. The status of the Regulate Cycle is represented by the progress bar on the Zoë display.

Note: Once the Regulate Cycle has started, there will be a sound as Zoë engages the Pods. Ensure the "tray buttons" are glowing blue.
 - d. The Regulate Cycle takes approximately 2 hours to finish. After the cycle has finished, the Zoë will begin flow at the preset Organ-Chip culture conditions.
 - e. To cancel the Regulate Cycle (only if needed):
 - i. Zoë displays a progress bar of the status of the Regulate Cycle; below the progress bar is the Cancel option.
 - ii. To cancel the Regulate Cycle, press the Dial Button to display the "Cancel confirmation" dialog.
 - iii. Rotate the Dial to highlight "Cancel Regulate" and press the Dial Button. Once the "Regulate Cycle Cancelled" appears on the Zoë UI use the Dial Button to click "Accept". Wait one minute and then trays can be removed.
 - iv. If a Regulate Cycle is cancelled, it is important to perform a complete Regulate Cycle before proceeding with your experiment.

TITLE	DOCUMENT EG-185	VERSION Rev A
Brain-Chip R1 Culture Guideline	DATE 11Mar2026	PAGE 57 OF 71

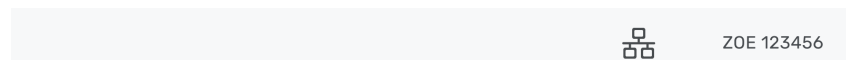
Prime Cycle
Regulate Cycle | Start

Flow  **Chip-R1**

LOCATION	MEDIA	RATE
Top	Liquid	20 $\mu\text{L}/\text{h}$
Bottom	Liquid	20 $\mu\text{L}/\text{h}$

Stretch

PARAMETER	RATE
Strain	0 %
Frequency	0 Hz



Figure 27. Image of the Zoë UI with Chip-R1 settings, flow for the top and bottom channels set to 20 $\mu\text{L}/\text{h}$, and the “start” button highlighted for selection for the regulate cycle.

Second Regulate Cycle

1. While the first regulate cycle runs, place at least 2.5 mL of Emulate Brain-Chip Brain Channel Medium for each chip in a 50 mL conical tube.
2. Place at least 2.5 mL of Base Vascular Channel Maintenance Medium for each chip in a separate 50 mL conical tube.
3. Warm both 50 mL conical tubes of media at 37°C in a water or bead bath for at least 1 hour.
4. After warming for 1 hour, de-gas media as explained previously. Set aside in an incubator or 37°C bead-bath.
 - a. Add Human Serum (PPP) to the Base Vascular Channel Maintenance Medium to make Complete Vascular Channel Maintenance Medium as previously explained.
5. Once the first regulate cycle is completed, stop flow on the Zoë by pressing the silver “Activation” button(s). There will be an audible click once pressed, signifying the Pod-Chip units will be disengaged.
6. Remove the tray(s) of Pod-Chips from the Zoë and bring to the BSC.
7. Aspirate out all the media from both top and bottom inlet reservoirs.
8. Aspirate out most of the media from the top and bottom outlet reservoirs, ensure that at least 300 μL of media remains over the vias and that they are completely submerged.
9. Pipette 2 mL of equilibrated, warm media to each inlet reservoir. In the top channel inlet reservoir, add Emulate Brain-Chip Brain Channel Medium; in the bottom channel inlet reservoir, add Complete Vascular Channel Maintenance Medium.
10. Perform via washes on all Pod reservoirs.
11. Bring trays containing Pod-Chips to the incubator and slide them completely into the Zoë with the tray handle facing outward.

TITLE	DOCUMENT	VERSION
Brain-Chip R1 Culture Guideline	EG-185	Rev A
	DATE	PAGE
	11Mar2026	58 OF 71

12. Run the Regulate Cycle again (as previously described) and allow the flow to continue overnight.
 - a. **Note:** Confirm flow for top and bottom are set at 20 μ L/h prior to start the second regulate cycle.

TITLE	DOCUMENT	VERSION
Brain-Chip R1 Culture Guideline	EG-185	Rev A
	DATE	PAGE
	11Mar2026	59 OF 71

Day 4: Monolayer Stabilization

Goals:

- Bottom Channel BMEC monolayer stabilization post-connection
- Top Channel brain cell culture stabilization post-connection

Key Steps:

- Replenish media in the top and bottom inlet and outlet reservoirs

Required Materials:

- Installed and qualified Zoë
- Pod-Chip Units
- Tray—1 per 6 Pod-Chip Units
- Steriflip filtration unit: PVDF filter 0.45 µm (sterile), 1 for each media
- Vacuum source (minimum -70 kPa)
- Emulate Brain-Chip Brain Channel Medium
- Emulate Brain-Chip Vascular Channel Medium
- B27
- Human Serum (PPP)
- Serological pipettes
- Pipettors and filtered tips
- 37°C water or bead bath
- 70% ethanol

Media Preparation

1. Place at least 2.5 mL of Emulate Brain-Chip Brain Channel Medium for each chip in a 50 mL conical tube.
2. Prepare at least 2.5 mL of Base Vascular Channel Maintenance Medium for each chip in a separate 50 mL conical tube.
3. Warm both 50 mL conical tubes of media at 37°C in a water or bead bath for at least 1 hour.
4. After warming for 1 hour, de-gas media as explained previously. Set aside in an incubator or 37°C bead-bath.
 - a. Add Human Serum (PPP) to the Base Vascular Channel Maintenance Medium to make Complete Vascular Channel Maintenance Medium as previously explained.

TITLE	DOCUMENT	VERSION
Brain-Chip R1 Culture Guideline	EG-185	Rev A
	DATE	PAGE
	11Mar2026	60 OF 71

Media Replenishment

1. The day after connecting chips and Pods to Zoë, which begins the process of Organ-Chip culture, pause the Zoë by pressing the silver “Activation” button located above the tray bays. This stops flow and releases the Pod-Chip units.
2. Slide the tray out of the bay and transfer it to the BSC.
3. Remove the Pod lids and aspirate all media from all top and bottom inlet and outlet reservoirs.
4. Pipette 2 mL of equilibrated, warm media to each inlet reservoir. In the top channel inlet reservoir, add Emulate Brain-Chip Brain Channel Medium; in the bottom channel inlet reservoir, add Complete Vascular Channel Maintenance Medium.
5. Replace Pod lids and bring trays containing Pod-Chips to the incubator.
6. Slide trays completely into the Zoë with the tray handle facing outward.
7. Confirm Organ-Chip culture settings (Chip-R1, top & bottom flow: 20 μ L/h) and press the silver “Activation” button(s) to start flow.

TITLE	DOCUMENT	VERSION
Brain-Chip R1 Culture Guideline	EG-185	Rev A
	DATE	PAGE
	11Mar2026	61 OF 71

Days 5-9: Experimental Phase

Goals:

- Assess BMEC morphology, barrier integrity, cellular markers
- Assess brain cell morphology, neuroinflammatory cytokine levels, cellular markers

Key Steps:

- Replenish media in the top and bottom inlet and outlet reservoirs
- Assess cellular morphology via brightfield imaging
- Assess barrier integrity using Papp measurements of a known tracer
- Evaluate neuroinflammatory cytokine levels via effluent sampling
- Evaluate cellular markers and tight junctions via immunofluorescence staining

Required Materials:

- Installed and qualified Zoë™
- Pod-Chip Units
- Tray—1 per 6 Pod-Chip Units
- Steriflip filtration unit: PVDF filter 0.45 µm (sterile), 1 for each media
- Vacuum source (minimum -70 kPa)
- Emulate Brain-Chip Brain Channel Medium
- Emulate Brain-Chip Vascular Channel Medium
- B27
- Human Serum (PPP)
- Casacde Blue, 3 kDa, Dextran
- 4% paraformaldehyde
- 96 deep-well plates
- Serological pipettes
- Pipettors and filtered tips
- 37°C water or bead bath
- 70% ethanol

Sampling and Media Replenishment

1. Pause Zoë by pressing the silver “Activation” button.
2. Remove the trays and place them in the BSC.
3. Inspect each chip for bubbles by eye.
4. Using a microscope, inspect chips for the presence of bubbles in the channels, and inspect cells in the chips to assess morphology and viability. Capture representative images at 10X or 20X magnification at the following locations (Figure 28):
 - Inlet junction
 - Center of channel (2-3x)
 - Outlet junction

TITLE Brain-Chip R1 Culture Guideline	DOCUMENT EG-185	VERSION Rev A
	DATE 11Mar2026	PAGE 62 OF 71

5. Remove the Pod lids and collect effluent medium from Pod inlet and outlet reservoirs for analysis. Collect effluent from the indicated regions, avoiding disturbing the Pod reservoir vias.
 - Collect effluent into a 96 deep-well plate and store appropriately. For long-term storage, cover plate with a foil sticker and lid, then place in a -80°C freezer.
 - If collecting for cytokine secretion analysis, include 0.1% BSA into each sample, seal the plate, and store in a -80°C freezer. For processing, allow samples to thaw overnight at 4°C .
6. Gently aspirate any medium not collected for analysis, ensuring that a thin liquid film still covers the reservoir vias so that no air is introduced into the vias.
7. Refill the Pod media reservoirs with appropriate fresh cell culture medium and perform a via wash: Using medium within the Pod reservoir, pipette 1 mL of medium directly over the top of the via to dislodge any bubbles that may be present.
8. Replace the Pod lids and return trays to Zoë.
9. Press the silver “Activation” button to resume pre-set Organ-Chip culture conditions.
10. Zoë will engage when the “Activation” button glows blue.

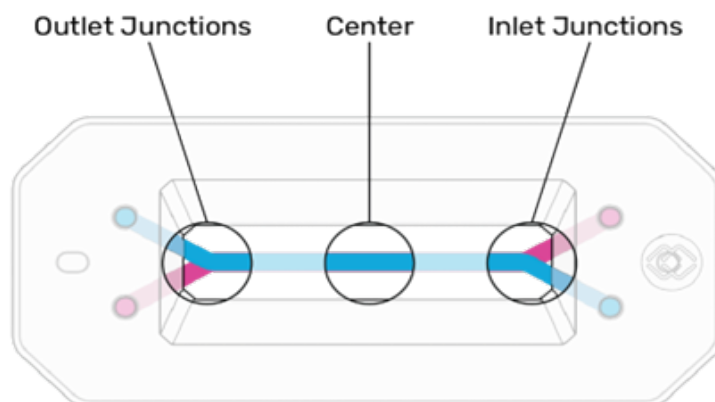

Figure 28. Diagram of a Chip-R1 and the recommended areas to take brightfield images to assess cell health of the top and bottom channels.

Barrier Integrity

1. Pause Zoë by pressing the silver “Activation” button.
2. Remove the trays and place them in the BSC.
3. Aspirate bottom channel inlet and outlet reservoirs of the Pod(s).
4. Make barrier tracer solution:
 - a. Cascade Blue, 3 kDa, Dextran
 - i. Reconstitute Cascade Blue to a stock concentration of 3.33 mM with DPBS 1x.
 - b. Add Cascade Blue to warmed, equilibrated Complete Vascular Channel Maintenance Medium with final concentrations of $33.3\ \mu\text{M}$.

TITLE	DOCUMENT EG-185	VERSION Rev A
Brain-Chip R1 Culture Guideline	DATE 11Mar2026	PAGE 63 OF 71

5. Pipette 2 mL of Complete Vascular Channel Maintenance Medium with tracers to the bottom inlet reservoirs.
6. Pipette 2 mL of warmed, equilibrated Emulate Brain-Chip Brain Channel Medium to the top inlet reservoirs.
7. Replace Pod lids and return tray(s) to the Zoë.
8. Press the silver “Activation” button(s) to start Organ-Chip culture.
 - a. Set aside 2 mL of Complete Vascular Channel Maintenance Medium and 1 mL of Emulate Brain-Chip Brain Channel Medium with Cascade Blue.
 - b. Store in the incubator with the Pod-Chip Units.
9. Allow enough time to pass so at least 150 μ L flows from inlet to outlet in the bottom and top channels (roughly 8 h).
10. Collect effluents from top and bottom channel inlets and outlets.
 - a. Add 100 μ L of each sample to a 96-well plate for plate reading.
 - b. Set up a standard curve using the leftover media (+/- tracers) stored in the incubator and add to the 96-well plate.
 - c. Run the plate in a plate reader.
 - d. Plug OD values to the barrier calculator and evaluate barrier integrity.
 - e. Plates can be stored at 4°C.
11. Replenish media and return to Zoë for continued Organ-Chip culture.

Experimental Takedown

The end of the experimental phase is on Day 9, and chips can be taken down for immunofluorescence imaging or other downstream processing, like RT-qPCR.

1. Pause Zoë by pressing the silver “Activation” button.
2. Remove the trays and place them in the BSC.
3. Aspirate top and bottom channel inlet and outlet reservoirs (unless collecting for barrier or other effluent analyses).
4. For immunofluorescence processing:
 - a. Add 500 μ L of 4% PFA to the inlet reservoirs for the top and bottom channels.
 - b. Flow both top and bottom channels at 1000 μ L/h for 5 minutes.
 - c. Stop flow and incubate for 5 minutes.
 - d. Aspirate the inlet and outlet reservoirs.
 - e. Replace with 500 μ L of DPBS 1x in the inlet reservoirs.
 - f. Flow both top and bottom channels at 1000 μ L/h for 10 minutes.
 - g. Stop flow and aspirate the inlet and outlet reservoirs.
 - h. Add fresh DPBS 1x to both inlet and outlet reservoirs (500 μ L).
 - i. Store Pod-Chip units at 4°C.

Note: All handling of 4% PFA should be done in a fume hood and disposed separately from normal liquid waste.
 - j. Chips are ready for PFA-fixed immunofluorescence staining protocols.
5. For RNA or DNA collection:

TITLE	DOCUMENT	VERSION
Brain-Chip R1 Culture Guideline	EG-185	Rev A
	DATE	PAGE
	11Mar2026	64 OF 71

- a. Disconnect chips from Pods.
 - b. With a P200 pipette, carefully insert a pipette tip with 100 μ L of RNA/DNA lysis buffer into the bottom channel inlet and eject the tip. Add an empty tip to the bottom channel outlet.
 - c. Repeat the same for the top channel.
 - d. Incubate a few minutes, then strongly pipette the lysis solution in the top channel. Check the state of the top channel cells under a microscope. If the cells have been properly broken open, collect everything from the top channel in a 1.5 mL Eppendorf tube on ice.
 - e. Repeat the same for the bottom channel.
 - f. Label and store Eppendorf tubes in a -80°C freezer for later downstream processing.
 - g. Discard chips.
6. For protein collection:
 - a. Disconnect chips from Pods.
 - b. With a P200 pipette, carefully insert a pipette tip with 100 μ L of cell lysis buffer into the bottom channel inlet and eject the tip. Add an empty tip to the bottom channel outlet.
 - c. Repeat the same for the top channel.
 - d. Incubate a few minutes, then strongly pipette the lysis solution in the top channel. Check the state of the top channel cells under a microscope. If the cells have been properly broken open, collect everything from the top channel in a 1.5 mL Eppendorf tube on ice.
 - e. Repeat the same for the bottom channel.
 - f. Label and store Eppendorf tubes in a -80°C freezer for later downstream processing.
 - g. Discard chips.
 7. For whole cell collection:
 - a. Disconnect chips from Pods.
 - b. With a P200 pipette, carefully insert a pipette tip with 100 μ L of TrypLE Express into the bottom channel inlet and eject the tip. Add an empty tip to the bottom channel outlet.
 - c. Repeat the same for the top channel.
 - d. Incubate a few minutes, then strongly pipette the TrypLE solution in the top channel. Check the state of the top channel cells under a microscope. If the cells have lifted, collect everything from the top channel in a 1.5 mL eppendorf on ice.
 - e. Repeat the same for the bottom channel.
 - f. Label and store Eppendorf tubes in a -80°C freezer for later downstream processing.
 - g. Discard chips.

TITLE	DOCUMENT EG-185	VERSION Rev A
Brain-Chip R1 Culture Guideline	DATE 11Mar2026	PAGE 65 OF 71

Troubleshooting

Issue	Section	Step	Recommendation
Bubbles are present in channel	Chip Preparation	Coat Chips with ECM	Dislodge by washing the channel with appropriate solution until all bubbles have been removed. If bubbles persist, it may be helpful to aspirate the channel dry and slowly reintroduce the solution.
Bubbles in the ports upon introduction of media into the chip	Chips to Pods and Pods to Zoë	Wash Chips	Since the chip material is hydrophobic, bubbles could get trapped at the ports. Dislodge bubbles using pipette tip or dispense new, equilibrated media into the channels.
Media take too long to pass through Steriflip	Chips to Pods and Pods to Zoë	Equilibration of Media	Vacuum pressure is not reaching -70kPa. Need to find an alternate vacuum source.
Pods do not prime	Chips to Pods and Pods to Zoë	Prime Pods	Ensure that medium is directly over all Pod vias. If problem persists, record the Pod lot number, and replace it with a new Pod.
Screen is frozen or unresponsive	Chips to Pods and Pods to Zoë; Maintaining and Sampling	Pod to Zoë; Maintenance and Regulate	Power off Zoë and then turn Zoë on again; contact our support team if a problem persists.
Pods stuck in Zoë	Maintaining and Sampling	Maintenance and Regulate	Pod lid not secured on Pod. Try wiggling the tray to the right and left as you slide it out while keeping it level. If the problem persists, contact our support team.
Pods not flowing properly or evenly; Bubbles observed in chip	Maintaining and Sampling	Maintenance and Regulate	There is inherent variability with Zoë ¹ , however, large fluctuations and major flow issues primarily result from bubbles. Remove chip from Pod; flush chip with media; re-prime Pod with degassed media; connect chip to Pod; and run the Regulate Cycle.

TITLE Brain-Chip R1 Culture Guideline	DOCUMENT EG-185	VERSION Rev A
	DATE 11Mar2026	PAGE 66 OF 71

Potential Root Causes of Bubbles

Check the following if a high failure rate due to bubbles is observed or if bubbles are persistent, despite following the mitigation steps above.

- Medium not sufficiently equilibrated before adding to Pods: Be sure to follow media preparations steps in section Gas Equilibration of Media.
- Vacuum for Steriflip too weak: Ensure that media is passing through the Steriflip in about 10 seconds.
- Incorrect Steriflip used: Confirm correct Steriflip unit (Millipore SE1M003M00).
- Medium not warmed correctly before Steriflip step: Be sure to follow media preparations steps in section Gas Equilibration of Media.
- Insufficient priming: Disconnect chip and reprime Pod.

Images of Bubbles in Chip

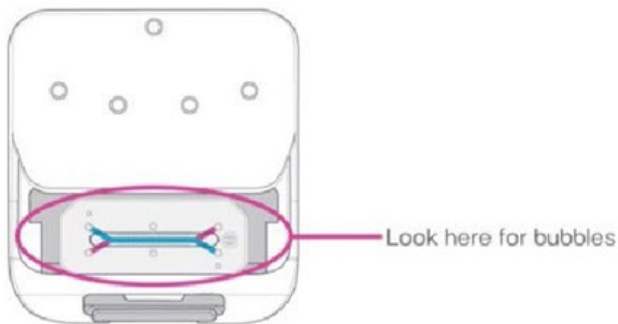

Channels filled with fluid

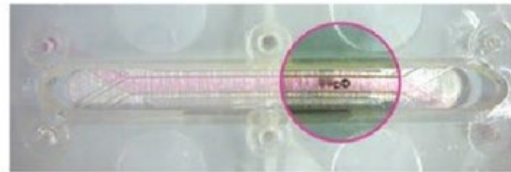

Small bubbles in Top Channel



Both Channels dry

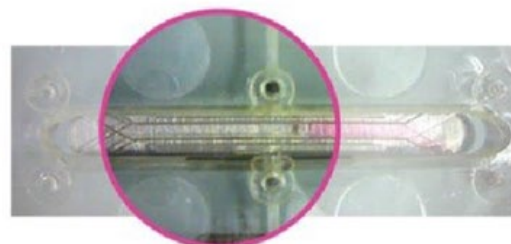

Bubble plug in Top Channel

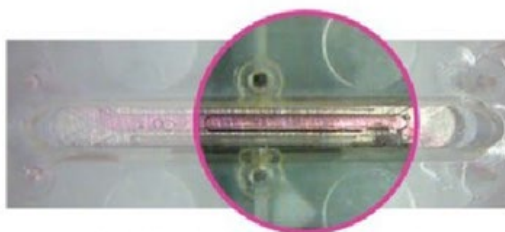

Bubble plug in Bottom Channel

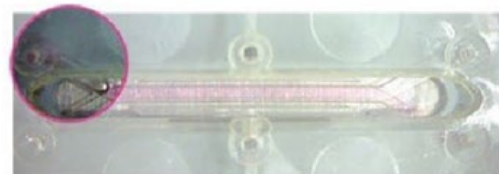

Bubble plug in Top Seeding

TITLE	DOCUMENT EG-185	VERSION Rev A
Brain-Chip R1 Culture Guideline	DATE 11Mar2026	PAGE 67 OF 71

Appendices

Reagent Aliquots

Aliquot the reagents before use to avoid multiple freeze-thaw cycles of the stock solutions.

Extracellular Matrix (ECM) Components

Reagent	Source	Catalogue Number	Conc. [Stock]	Amount	Volume	Solvent	Storage
Fibronectin	Corning	356008	1 mg / mL	5 mg	5 mL	Cell culture grade water	-20°C
Laminin	Sigma	CC095-5MG	Variable	5 mg	5 mL	-	-20°C
Collagen IV	Sigma	C5533-5MG	1 mg / mL	5 mg	5 mL	Cell culture grade water	-20°C

- Resuspend ECM according to manufacturer's instructions.
- Aliquot to single-use volumes and store at -20°C.

Supplements for Vascular Channel Seeding and Maintenance Media

Reagent	Source	Catalogue Number	Conc. [Stock]	Volume	Solvent	Storage
B27	GIBCO	17504-044	50X	10 mL	-	-20°C
Human Serum (PPP)	Sigma	P2918-20ML	100%	20 mL	-	-20°C

- Aliquot each supplement to single-use volumes.
- Store aliquots as indicated. Those stored at -20°C can be thawed at 4°C and maintained for up to one week.

General Seeding Supplements

Reagent	Source	Cat #	Conc. [Stock]	Mass	Volume	Solvent	Storage
Y-27632 (ROCKi)	StemCell	72304 5MG	0.01M	5 mg	1.56 mL	DPBS (1X)	-20°C
CNTF	PeproTech	450-13-20UG	100 µg/mL	20 µg	200 µL	Cell Culture Grade Water	-20°C

- Resuspend each supplement to the stock concentration in the table above or according to manufacturer's instructions, if need be.
- Aliquot each supplement to single-use volumes and store at -20°C.

TITLE Brain-Chip R1 Culture Guideline	DOCUMENT EG-185	VERSION Rev A
	DATE 11Mar2026	PAGE 68 OF 71

Barrier Tracer

Reagent	Source	Cat #	Conc. [Stock]	Mass	Volume	Solvent	Storage
Cascade Blue	ThermoFisher	D7132	3.33 mM	10 mg	1 mL	DPBS (1X)	-20°C

- Resuspend to the stock concentration in the table above or according to manufacturer's instructions, if need be.
- Aliquot to single-use volumes and store at -20°C.

Media Recipes

Media Timeline

Day	-1	0	1	2	3	4	5+
Bottom Channel	-	Base and Complete Vascular Channel Seeding Medium	Complete Vascular Channel Medium	Base and Complete Vascular Channel Maintenance Medium			
Top Channel	Emulate Brain-Chip Brain Channel Medium			Complete Brain Channel Pericyte Seeding Medium Complete Brain Channel Seeding Medium	Emulate Brain-Chip Brain Channel Medium		
				Emulate Brain-Chip Brain Channel Medium			

***Prepared with added supplements**

***No added supplements; media straight from the stock bottle**

Bottom Channel Media

Base Vascular Channel Seeding Medium (Day 0)

Reagent	Conc. [Stock]	Conc. [Final]	Source	Cat. No.
Emulate Brain-Chip Vascular Channel Medium	-	-	FUJIFILM Cellular Dynamics, Inc.	RGT-BRVC-150
Human Serum (PPP)	100%	5%	Sigma	P2918

- Warm the Emulate Brain-Chip Vascular Channel Medium for 1 hr at 37°C prior to adding the Human Serum (PPP). Maintain at 37°C.
- Add the Human Serum (PPP) when prepared to wash chips.
 - **Note:** Do not filter or mix the Human Serum (PPP) prior to adding to the medium.
- Use the day of preparation.

TITLE Brain-Chip R1 Culture Guideline	DOCUMENT EG-185	VERSION Rev A
	DATE 11Mar2026	PAGE 69 OF 71

Complete Vascular Channel Seeding Medium (Day 0)

Reagent	Conc. [Stock]	Conc. [Final]	Source	Cat. No.
Emulate Brain-Chip Vascular Channel Medium	-	-	FUJIFILM Cellular Dynamics, Inc.	RGT-BRVC-150
Human Serum (PPP)	100%	5%	Sigma	P2918
Y-27632 (ROCK Inhibitor)	10 mM	10 μ M	StemCell	72304

- Warm the Emulate Brain-Chip Vascular Channel Medium for 1 hr at 37°C prior to adding the Human Serum (PPP) or ROCKi. Maintain at 37°C.
- Add the Human Serum (PPP) when prepared to wash chips.
 - **Note:** Do not filter or mix the Human Serum (PPP) prior to adding to the medium.
- Add ROCK inhibitor when prepared to begin thawing and seeding BMECs.
- Use the day of preparation.

Complete Vascular Channel Medium (Day 1)

Reagent	Conc. [Stock]	Conc. [Final]	Source	Cat. No.
Emulate Brain-Chip Vascular Channel Media	-	-	FUJIFILM Cellular Dynamics, Inc.	RGT-BRVC-150
Human Serum (PPP)	100%	5%	Sigma	P2918

- Maintain at 37°C prior to use.
- Add the Human Serum (PPP) to the Emulate Brain-Chip Vascular Channel Medium when prepared to wash chips.
 - **Note:** Do not filter or mix the Human Serum (PPP) prior to adding to the medium.
- Prepare fresh for each use.

Base Vascular Channel Maintenance Medium (Day 2+)

Reagent	Conc. [Stock]	Conc. [Final]	Source	Cat. No.
Emulate Brain-Chip Vascular Channel Medium	-	-	FUJIFILM Cellular Dynamics, Inc.	RGT-BRVC-150
B27	50X	1X	Gibco	17504-044

- Maintain at 37°C prior to use.
- If only B27 is added to the Emulate Brain-Chip Vascular Channel Medium, media can be stored at 4°C and must be used within 15 days of preparation.

TITLE Brain-Chip R1 Culture Guideline	DOCUMENT EG-185	VERSION Rev A
	DATE 11Mar2026	PAGE 70 OF 71

Complete Vascular Channel Maintenance Medium (Days 2+)

Reagent	Conc. [Stock]	Conc. [Final]	Source	Cat. No.
Emulate Brain-Chip Vascular Channel Medium	-	-	FUJIFILM Cellular Dynamics, Inc.	RGT-BRVC-150
B27	50X	1X	Gibco	17504-044
Human Serum (PPP)	100%	2%	Sigma	P2918

- Maintain at 37°C prior to use.
- If only B27 is added to the Base Vascular Channel Medium, media can be stored at 4°C and must be used within 15 days of preparation.
- Add the B27 and Human Serum (PPP) to the Emulate Brain-Chip Vascular Channel Medium when prepared to add droplets, wash chips, or replenish Pod-Chip units.
 - **Note:** Do not filter or mix the Human Serum (PPP) prior to adding to the medium.
- Media with Human Serum (PPP) must be prepared fresh for each use.

Top Channel Media
Complete Brain Channel Pericyte Seeding Medium (Day 2)

Reagent	Conc. [Stock]	Conc. [Final]	Source	Cat. No.
Emulate Brain-Chip Brain Channel Medium	-	-	FUJIFILM Cellular Dynamics, Inc.	RGT-BRBC-150
Y-27632 (ROCK Inhibitor)	10 mM	10 µM	StemCell	72304

- Maintain at 37°C prior to use.
- Add the ROCKi to the Emulate Brain-Chip Brain Channel Medium when prepared to thaw and seed pericytes.
- Prepare fresh for each use.

Complete Brain Channel Seeding Medium (Day 2)

Reagent	Conc. [Stock]	Conc. [Final]	Source	Cat. No.
Emulate Brain-Chip Brain Channel Medium	-	-	FUJIFILM Cellular Dynamics, Inc.	RGT-BRBC-150
Recombinant Human CNTF	100 µg/mL	10 ng/mL	PeproTech	450-13-20UG

- Maintain at 37°C.
- Add the CNTF to the Emulate Brain-Chip Brain Channel Medium when prepared to thaw and seed astrocytes, GABANeurons, and microglia.
- Prepare fresh for each use.

TITLE	DOCUMENT	VERSION
Brain-Chip R1 Culture Guideline	EG-185	Rev A
	DATE	PAGE
	11Mar2026	71 OF 71

© Emulate, Inc., 2026. All rights reserved.

Emulate®, the Emulate logo, Zoë-CM2®, and Orb-HM1® are registered trademarks of Emulate, Inc.

Chip-R1™ and Pod-2™ are trademarks of Emulate, Inc.

Steriflip is a registered trademark of Merck KGaA, Darmstadt, Germany.

Eppendorf® and Eppendorf Tubes® are registered trademarks of Eppendorf AG, Germany.

Parafilm® is a registered trademark of Bemis Company, Inc.

The technology disclosed in this document may be covered by one or more patents or patent applications owned by or licensed to Emulate, Inc. No license is granted herein. You are solely responsible for determining whether you have all intellectual property rights that are necessary for your intended use of Emulate products or guidelines, and whether you are required to obtain any additional intellectual property rights from a third party. Further information is available by contacting Emulate.